

Light Duty Incremental Encoders (SAE Dimension Encoders)

TRDA-2E series

Features

A light duty encoder that is cost-effective for small applications; has the following features:

- Small body with 1.5 in. diameter and 1.6 in. depth
- 0.25 in. diameter solid shaft
- Resolution available from 100 pulses per revolution to 2500 pulses per revolution
- Open collector or line driver output
- Up to 200kHz response frequency
- Two-meter cable with tinned ends
- IP50 environmental rating



TRDA-2Exxx-BD models



TRDA-2Exxx-VD models

Incremental Light Duty Solid-shaft Encoders (NPN Open-collector Output, TRDA-2ExxxBD)					
Part Number	Price	Pulses per Revolution	Input Voltage	Output	Body Dia.
TRDA-2E100BD	\$96.00	100	12–24 VDC	NPN Open Collector	1.5 in.
TRDA-2E360BD	\$96.00	360			
TRDA-2E500BD	\$96.00	500			
TRDA-2E1000BD	\$96.00	1000			
TRDA-2E1024BD	\$96.00	1024			
TRDA-2E2500BD	\$96.00	2500			

Incremental Light Duty Solid-shaft Encoders (Line-driver Output, TRDA-2ExxxVD)					
Part Number	Price	Pulses per Revolution	Input Voltage	Output	Body Dia.
TRDA-2E100VD	\$96.00	100	5VDC	Line Driver (differential)	1.5 in.
TRDA-2E360VD	\$96.00	360			
TRDA-2E500VD	\$96.00	500			
TRDA-2E1000VD	\$96.00	1000			
TRDA-2E1024VD	\$96.00	1024			
TRDA-2E2500VD	\$96.00	2500			

Accessories

Accessories for TRDA-2E Series Encoders		
Part Number	Price	Description
F-2D	\$36.00	Mounting flange, 1.86 inch bolt hole circle (1.05 inch height), metal. For use with Koyo TRDA-2E series encoders. Flange and encoder mounting hardware included.
F-3D	\$36.00	Mounting flange, 2.95 inch bolt hole circle (1.34 inch height), metal. For use with Koyo TRDA-2E series encoders. Flange and encoder mounting hardware included.
F-6D	\$36.00	Mounting flange, 1.86 inch bolt hole circle (1.34 inch height), metal. For use with Koyo TRDA-2E series encoders. Flange and encoder mounting hardware included.
F-7D	\$36.00	Mounting flange, 1 inch bolt hole circle (0.20 inch height), metal. For use with Koyo TRDA-2E series encoders. Flange and encoder mounting hardware included.
F-8D	\$36.00	Mounting flange, 2.95 inch bolt hole circle (1.71 inch height), metal. For use with Koyo TRDA-2E series encoders. Flange and encoder mounting hardware included.
2ET-035D	\$39.50	Mounting bracket for TRDA-2E series encoders

Couplings

For encoders with a solid shaft, please select a coupling that fits your encoder. All couplings are in stock, ready to ship. See the “Encoder Couplings” section for more information.



2ET-035D



F-2D



F-3D



F-6D



F-7D



F-8D

Light Duty Incremental Encoders (SAE Dimension Encoders)

Specifications – TRDA-2E series

Electrical Specifications (SAE Dimension Light Duty)				
Model		TRDA-2ExxxxBD (open collector)	TRDA-2ExxxxVD (line driver)	
Power Supply	Operating Voltage *	12–24 VDC (nominal) * Range: 10.8–26.4 VDC	5VDC (nominal) * Range: 4.75–5.25 VDC	
	Allowable Ripple	3% rms max.		
	Current Consumption	50mA max. no load		
Output Waveform	Signal Waveform	Quadrature + home position		
	Max. Response Frequency	200kHz		
	Operating Speed	(max response frequency / resolution) x 60		
	Duty Ratio (Symmetry)	50% ±25%		
	Index Signal Width (at Home Position)	100% ±50%		
Output	Rise/Fall Time **	1µs max. **	100 ns max. **	
	Output Type	Open collector (NPN sinking)	Line driver (26C31 or equivalent)	
	Output Logic	Negative logic (active low)	Positive logic (active high)	
	Output Current	Inflow	30mA max.	20mA max.
		Outflow	–	
	Output Voltage	H	–	2.5 V min.
		L	0.4 V max.	0.5 V max.
	Load Power Supply Voltage	30VDC max.		–
Short-circuit Protection	Between each output and 0V		–	
* To be supplied by Class II source. ** With a cable of 2m or less; Max load.				
Mechanical Specifications				
Starting Torque	0.01 N·m [0.09 lb·in] max. @ 20 °C [68 °F]			
Max. Allowable Shaft Load	Axial: 20N [4.5 lb]; Radial: 30N [6.7 lb]			
Max. Allowable Speed	5000 rpm (highest speed that can support the mechanical integrity of encoder)			
Wire Size	26 AWG, shielded, oil-resistant PVC			
Mounting Orientation	can be mounted in any orientation			
Weight	approx. 170g [6.0 oz] (with 2m cable)			
Environmental Specifications				
Ambient Temperature	-10 to 70 °C [-14 to 158 °F]			
Storage Temperature	-25 to 85 °C [-13 to 185 °F]			
Operating Humidity	35–85% RH (non-condensing)			
Voltage Withstand	630V grounded through capacitor (a 630V cap is connected between 0V & FG lines)			
Insulation Resistance	50 MΩ min. (excluding shield)			
Vibration Resistance	durable for one hour along three axes @ 10 to 55 Hz with 0.75 mm half-amplitude			
Shock Resistance	490 m/s ² (11 ms applied three times along three axes)			
Protection	IP50			
Agency Approvals	cUL _{US} (E189395)			

Light Duty Incremental Encoders (SAE Dimension Encoders)

Specifications – TRDA-2E series

Wiring Diagrams

Open Collector Connections

Cable shield is connected to the encoder body (frame ground)

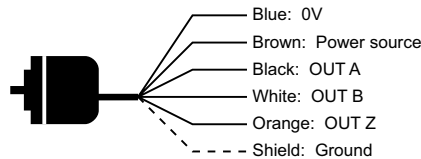

Line Driver Connections

Cable shield is connected to the encoder body (frame ground)

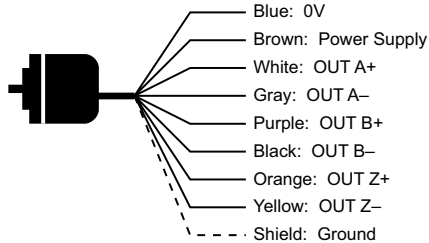

How to read the timing charts

Open Collector Models (TRDA-2ExxxBD)

Out A and Out B are 90 degrees out of phase. Like any quadrature encoder, four unique logic states are created internally to the encoder. This is based on the rising edge to rising edge (one cycle) on channel A or B that indicates one set of bars on the internal encoder disk has passed by the optical sensor.

OUT Z is the absolute reference added to an incremental encoder and is also known as home position. It signifies a full rotation of the encoder shaft.

Line Driver Models (TRDA-2ExxxVD)

Channel A (OUT A and A-not) and Channel B (OUT B and B-not) are also 90 degrees out of phase on line driver encoders. OUT Z is the same as on open collector models, and is the absolute reference (home position). It signifies one full rotation of the encoder shaft.

Channel Timing Charts

Open Collector Models (TRDA-2ExxxBD)

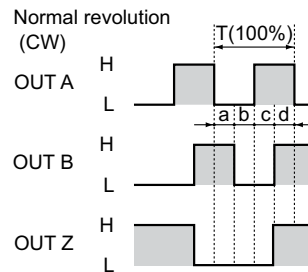

$a, b, c, d = 1/4T \pm 1/8T$
"Normal" means clockwise revolution viewed from the shaft

Line Driver Models (TRDA-2ExxxVD)

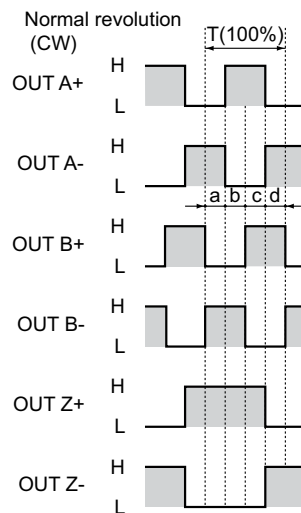

$a, b, c, d = 1/4T \pm 1/8T$
"Normal" means clockwise revolution viewed from the shaft

Light Duty Incremental Encoders (SAE Dimension Encoders)

Dimensions – TRDA-2E series

Dimensions = in [mm]

TRDA-2ExxxxD

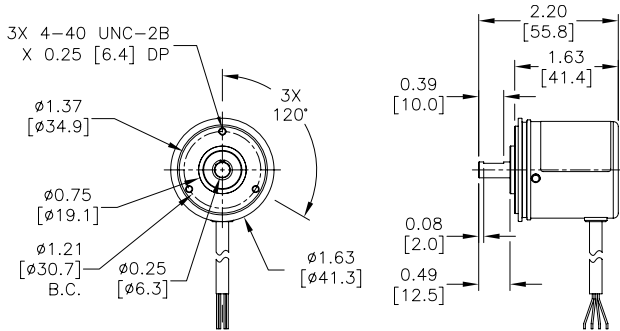

2ET-035D Mounting Bracket

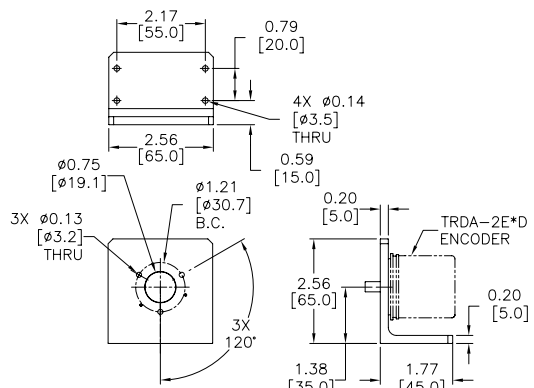

F-2D Mounting Flange

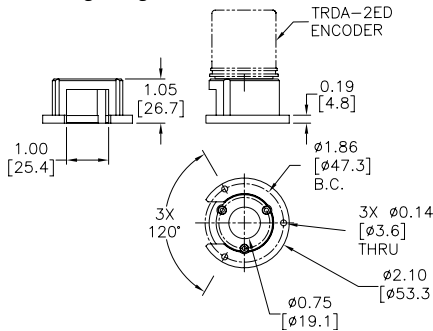

F-7D Mounting Flange

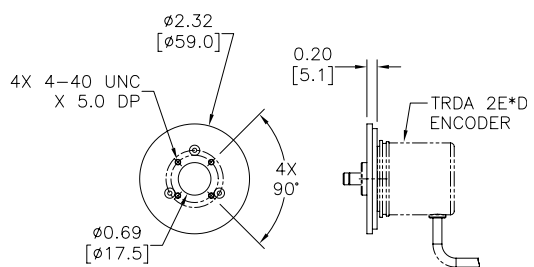

F-3D Mounting Flange

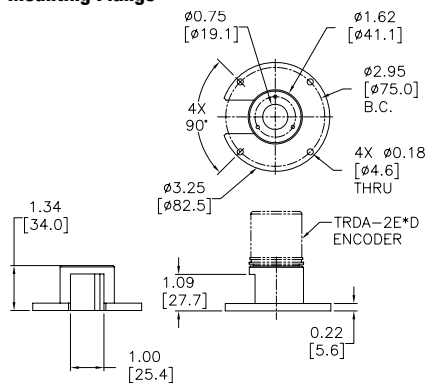

F-8D Mounting Flange

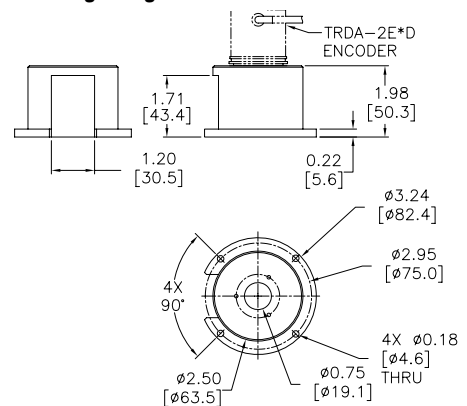

F-6D Mounting Flange

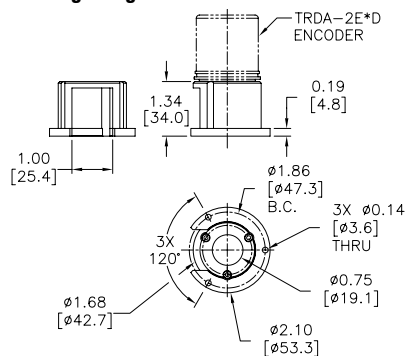

Light Duty Incremental Encoders (Metric Dimension Encoders)

TRD-MX series

Features

A light duty incremental rotary encoder that is cost-effective for small applications; has the following features:

- Small body with 25 mm diameter and 29 mm depth
- 4 mm diameter solid shaft
- Resolution available from 100 pulses per revolution to 1024 pulses per revolution
- Open collector output (4.5–13.2 or 10.8–26.4 VDC), or line driver output (4.75–5.25 VDC)
- Up to 100 kHz response frequency
- Two-meter cable with tinned ends
- IP50 environmental rating
- Mounting bracket and couplings are available



TRD-MXxxx-AD/BD models



TRD-MXxxx-VD models

Light Duty Solid-shaft Incremental Encoders (NPN Open-collector Output, TRD-MXxxxAD/BD)					
Part Number	Price	Pulses per Revolution	Input Voltage	Output	Body Dia.
TRD-MX100AD	\$92.00	100	4.5–13.2 VDC	NPN Open Collector	25 mm
TRD-MX360AD	\$92.00	360			
TRD-MX500AD	\$92.00	500			
TRD-MX1000AD	\$92.00	1000			
TRD-MX1024AD	\$92.00	1024			
TRD-MX100BD	\$92.00	100	10.8–26.4 VDC		
TRD-MX360BD	\$92.00	360			
TRD-MX500BD	\$92.00	500			
TRD-MX1000BD	\$92.00	1000			
TRD-MX1024BD	\$92.00	1024			

Light Duty Solid-shaft Incremental Encoders (Line Driver Output, TRD-MXxxxVD)					
Part Number	Price	Pulses per Revolution	Input Voltage	Output	Body Dia.
TRD-MX100VD	\$92.00	100	4.75–5.25 VDC	Line Driver	25 mm
TRD-MX360VD	\$92.00	360			
TRD-MX500VD	\$92.00	500			
TRD-MX1000VD	\$92.00	1000			
TRD-MX1024VD	\$92.00	1024			

Accessories

Accessories for TRD-MX Series Encoders		
Part Number	Price	Description
MM-4D	\$6.75	Servo mounting clamp for TRD-MX series encoders
MT-030D	\$22.50	Right-angle mounting bracket for TRD-MX series encoders



MM-4D



MT-030D

Couplings

For encoders with a solid shaft, please select a coupling that fits your encoder. All couplings are typically in stock, and ready to ship.

See the “Encoder Couplings” section for more information.



Couplings

Light Duty Incremental Encoders (Metric Dimension Encoders)

Specifications – TRD-MX series

Electrical Specifications (Metric Dimension Light Duty TRD-MX)					
Model		TRD-MXxxxAD (open collector)	TRD-MXxxxBD (open collector)	TRD-MXxxxVD (line driver)	
Power Supply	Operating Voltage *	5–12 VDC (nominal) * 4.5–13.2 VDC	12–24 VDC (nominal) * 10.8–26.4 VDC	5VDC (nominal) * 4.75–5.25 VDC	
	Allowable Ripple	3% rms max			
	Current Consumption	50 mA max (no load)			
	Circuit Protection Required	Limit current to 100 mA or less	–		
Output Waveform	Signal Waveform	Quadrature + home position			
	Max. Response Frequency	100 kHz			
	Operating Speed	(max response frequency / resolution) x 60 Hz			
	Duty Ratio (Symmetry)	50% ±25%			
	Index Signal Width (at Home Position)	100% ±50%			
Output	Rise/Fall Time **	2µs ** (sink current < 30 mA)		0.1 µs max ** (source current < 20 mA)	
	Output Type	Open collector (NPN sinking)		Line driver (26C31 or equivalent)	
	Output Logic	Negative logic (active low)		Positive logic (active high)	
	Output Current	Inflow	30 mA max		20 mA max
		Outflow	–		
	Output Voltage	H	–		2.5V min (source current < 20 mA)
		L	0.4V max (sink current < 30 mA)		0.5V max (source current < 20 mA)
	Load Power Voltage	30 VDC max		–	
Short-circuit Protection	–		–		
* To be supplied by Class II source. ** Cable length ≤2m or less. Maximum load.					
Mechanical Specifications (Metric Dimension Light Duty TRD-MX)					
Starting Torque	0.001 N·m [0.009 lb-in] max @ 20 °C [68 °F]				
Max. Allowable Shaft Load	Axial: 5N [1.1 lb]; Radial: 10N [2.2 lb]				
Max. Allowable Speed	6000 rpm (highest speed that can support the mechanical integrity of encoder)				
Wire Size	26 AWG, shielded, oil-resistant PVC				
Weight	approx 120g [0.3 lb]				
Environmental Specifications (Metric Dimension Light Duty TRD-MX)					
Ambient Temperature	-10 to 70 °C [14 to 158 °F]				
Storage Temperature	-25 to 85 °C [-13 to 185 °F]				
Operating Humidity	35–85% RH (non-condensing)				
Withstand Voltage *	630V grounded through capacitor (a 630V cap is connected between 0V & FG lines)				
Insulation Resistance	20 MΩ min				
Vibration Resistance	durable for one hour along three axes @ 10 to 55 Hz with 0.75 mm half-amplitude				
Shock Resistance	490 m/s ² (11 ms applied 3-times, each X, Y, Z)				
Mounting Orientation	can be mounted in any orientation				
Protection	IP50				
Agency Approvals	CE, RoHS, cUL _{US} (E189395)				
* Withstand voltage is good for power supply, signal, and case; not good for shield wire.					

Light Duty Incremental Encoders (Metric Dimension Encoders)

TRD-S(H) series

Features

A light duty encoder that is cost-effective for small applications and has the following features:

- Small body with 38 mm diameter and 30 mm depth
- Dust proof (IP40 rating)
- 6 mm solid shaft or 8 mm hollow shaft
- Resolution available from 100 pulses per revolution to 2500 pulses per revolution
- Open collector or line driver output
- Up to 200 kHz response frequency
- Two-meter cable, tinned ends



Solid-shaft (TRD-S) model



Hollow-shaft (TRD-SH) model

Light Duty Solid Shaft Incremental Encoders (NPN Open Collector and Line Driver models)					
Part Number	Price	Pulses per Revolution	Input Voltage	Output	Body Diameter
TRD-S100AD	\$97.00	100	5-12 VDC	NPN open collector	38mm
TRD-S360AD	\$97.00	360			
TRD-S500AD	\$97.00	500			
TRD-S1000AD	\$97.00	1000			
TRD-S1024AD	\$97.00	1024			
TRD-S2500AD	\$102.00	2500			
TRD-S100-BD	\$97.00	100	12-24 VDC	NPN open collector	
TRD-S200BD	\$97.00	200			
TRD-S250BD	\$97.00	250			
TRD-S300BD	\$97.00	300			
TRD-S360-BD	\$97.00	360			
TRD-S400BD	\$97.00	400			
TRD-S500-BD	\$97.00	500			
TRD-S600BD	\$97.00	600			
TRD-S800BD	\$97.00	800			
TRD-S1000-BD	\$97.00	1000			
TRD-S1024-BD	\$97.00	1024			
TRD-S1200BD	\$102.00	1200			
TRD-S2000BD	\$102.00	2000			
TRD-S2500-BD	\$102.00	2500			
TRD-S100-VD	\$97.00	100			
TRD-S200VD	\$97.00	200			
TRD-S250VD	\$97.00	250			
TRD-S300VD	\$97.00	300			
TRD-S360-VD	\$97.00	360			
TRD-S400VD	\$97.00	400			
TRD-S500-VD	\$97.00	500			
TRD-S600VD	\$97.00	600			
TRD-S800VD	\$97.00	800			
TRD-S1000-VD	\$97.00	1000			
TRD-S1024-VD	\$97.00	1024			
TRD-S1200VD	\$97.00	1200			
TRD-S2000VD	\$97.00	2000			
TRD-S2500-VD	\$97.00	2500			

Light Duty Hollow Shaft Incremental Encoders (NPN Open Collector and Line Driver models)					
Part Number	Price	Pulses per Revolution	Input Voltage	Output	Body Diameter
TRD-SH100AD	\$99.00	100	5-12 VDC	NPN open collector	38mm
TRD-SH360AD	\$99.00	360			
TRD-SH500AD	\$99.00	500			
TRD-SH1000AD	\$99.00	1000			
TRD-SH1024AD	\$99.00	1024			
TRD-SH2500AD	\$104.00	2500			
TRD-SH100-BD	\$99.00	100	12-24 VDC	NPN open collector	
TRD-SH200BD	\$99.00	200			
TRD-SH250BD	\$99.00	250			
TRD-SH300BD	\$99.00	300			
TRD-SH360-BD	\$99.00	360			
TRD-SH400BD	\$99.00	400			
TRD-SH500-BD	\$99.00	500			
TRD-SH600BD	\$99.00	600			
TRD-SH800BD	\$99.00	800			
TRD-SH1000-BD	\$99.00	1000			
TRD-SH1024BD	\$99.00	1024			
TRD-SH1200BD	\$104.00	1200			
TRD-SH2000BD	\$104.00	2000			
TRD-SH2500-BD	\$104.00	2500			
TRD-SH100-VD	\$99.00	100			
TRD-SH200VD	\$99.00	200			
TRD-SH250VD	\$99.00	250			
TRD-SH300VD	\$99.00	300			
TRD-SH360-VD	\$99.00	360			
TRD-SH400VD	\$99.00	400			
TRD-SH500-VD	\$99.00	500			
TRD-SH600VD	\$99.00	600			
TRD-SH800VD	\$99.00	800			
TRD-SH1000-VD	\$99.00	1000			
TRD-SH1024VD	\$99.00	1024			
TRD-SH1200VD	\$104.00	1200			
TRD-SH2000VD	\$104.00	2000			
TRD-SH2500-VD	\$104.00	2500			

Light Duty Incremental Encoders (Metric Dimension Encoders)

Specifications – TRD-S(H) series

Electrical Specifications					
Model		TRD-SxxxxAD TRD-SHxxxxAD (open collector)	TRD-Sxxxx-BD TRD-SHxxxxBD (open collector)	TRD-Sxxxx-VD TRD-SHxxxxVD (line driver)	
Power Supply	Operating Voltage *	5–12 VDC (nominal) * Range: 4.75–13.2 VDC	12–24 VDC (nominal) * Range: 10.8–26.4 VDC	5VDC (nominal) * Range: 4.75–5.25 VDC	
	Allowable Ripple	3% max.			
	Current Consumption	50 mA max.			
Signal Waveform		Quadrature + home position			
Max. Response Frequency		200kHz			
Operating Speed		(max response frequency / resolution) x 60			
Duty Ratio		50% ±25%			
Phase Difference Width		25% ±12.5%			
Signal Width at Home Position		100 ±50%			
Output	Rise/Fall Time	1µs max. (when cable length is 1m)		–	
	Output Type	NPN open collector output, sinking		Line driver output (26C31 or equivalent)	
	Output Logic	Negative logic (active low)		Negative logic (active high)	
	Output Voltage	H	–		2.5 V min.
		L	0.4 V max.		0.5 V max.
	Current	30mA max.		20 mA max.	
	Load Power Voltage	35 VDC max.		–	
Short-Circuit Protection	Between output and power supply		–		
* To be supplied by Class II source					
Mechanical Specifications					
Starting Torque	0.001 Nm (0.00074 ft/lb) max				
Max. Allowable Shaft Load	Radial: 20N (4.5 lb); Axial: 10N (2.25 lb)				
Max. Allowable Speed	6000 rpm (highest speed that can support the mechanical integrity of encoder)				
Wire Size	AWG26				
Mounting Orientation	can be mounted in any orientation				
Weight	approx. 150g (5.3 oz) with 2m cable				
Environmental Specifications					
Ambient Temperature	-10 to 70°C; 14 to 158°F				
Storage Temperature	-25 to 85°C; -13 to 185°F				
Operating Humidity	35–85% RH				
Withstand Voltage	500VAC (50/60Hz) for one minute				
Insulation Resistance	50MΩ min.				
Vibration Resistance	durable for one hour along three axes at 10 to 55 Hz with 0.75 amplitude				
Shock Resistance	11 ms with 490 m/s ² applied three times along three axes				
Protection	IP40				

Light Duty Incremental Encoders (Metric Dimension Encoders)

Dimensions – TRD-S(H) series

All dimensions in mm
1mm = 0.03937in

Solid-shaft models

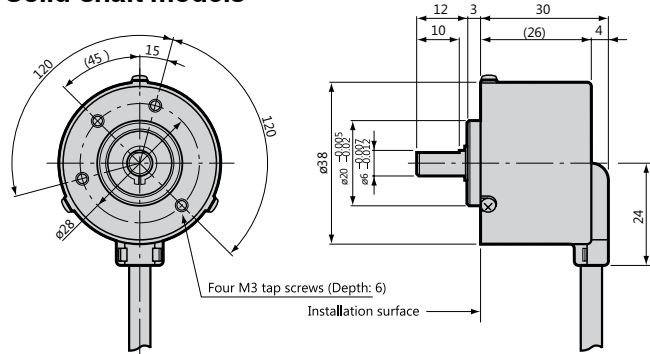

Hollow-shaft models

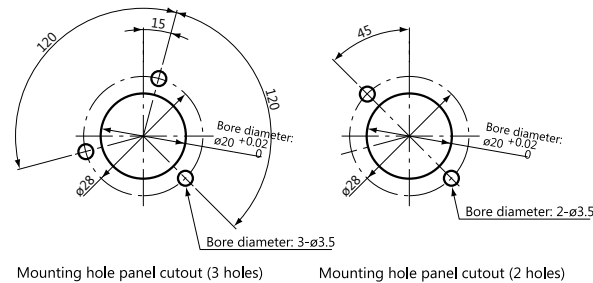
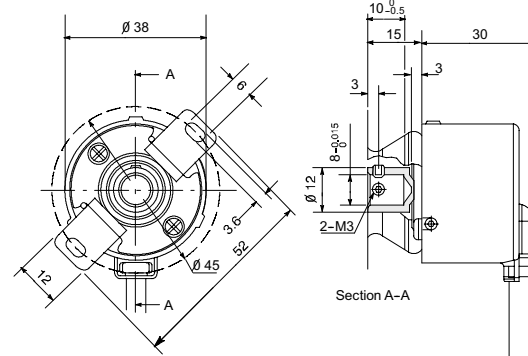

TRD-SH-BKT (bracket)

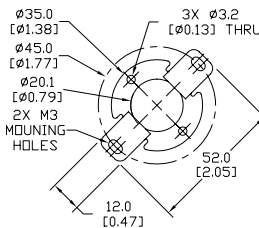

Mounting Accessories		
Part #	Price	Description
TRD-SH-BKT	\$5.50	Flexible mounting bracket, replacement. For use with Koyo TRD-SH series hollow shaft encoders

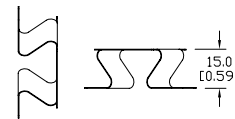

Wiring diagrams

Open collector connections

Cable shield is not connected to the encoder body; enclosure is grounded through the 0V wire

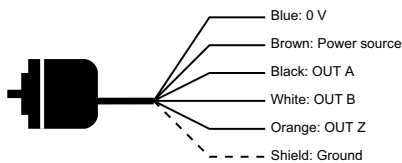

Line driver connections

Cable shield is not connected to the encoder body; enclosure is grounded through the 0V wire

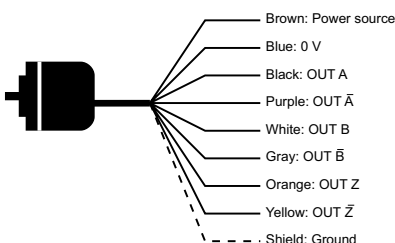

Channel timing charts

Open Collector Models

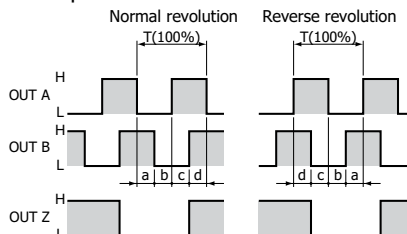

Line Driver Models

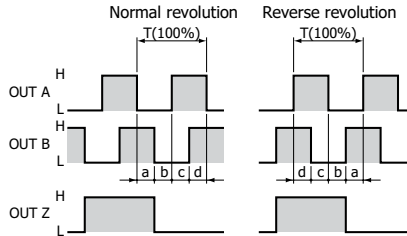

a, b, c, = 1/4T ± 1/8T
"Normal" means clockwise revolution viewed from the shaft.

How to read the timing charts

Open Collector Models

Out A and Out B are 90 degrees out of phase. Like any quadrature encoder, four unique logic states are created internally to the encoder. This is based on the rising edge to rising edge (one cycle) on channel A or B that indicates one set of bars on the internal encoder disk has passed by the optical sensor.

OUT Z is the absolute reference added to an incremental encoder and is also known as home position. It signifies a full rotation of the encoder shaft.

Line Driver Models

Channel A (OUT A and A-not) and Channel B (OUT B and B-not) are also 90 degrees out of phase in line driver encoders. OUT Z is the same as on open collector models, and is the absolute reference (home position). It signifies one full rotation of the encoder shaft.

Encoder Accessories – Couplings

Encoder Couplings

Couplings provide a connection between solid-shaft encoders and solid shafts. We offer aluminum, fiberglass, and polymer couplings for metric, S.A.E. and metric-to-S.A.E. applications.

Misalignment compensation

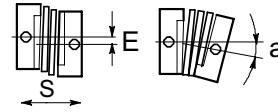

Couplings Selection Guide and Dimensions																
Type	Part Number	Price	Applicable Encoders (shaft size)	Shaft Diameter		D	L	F	C	M	a	E	S	Working Torque	Torsional Rigidity	Material
				d1	d2											
				max			(mm [in])				(N-m)					
Fiberglass (metric)	GJ-4D	\$9.75	TRD-MX (4mm)	4mm	4mm	13 [0.51]	21 [0.83]	5.3 [0.21]	3 [0.12]	M3 set screw	5°	0.4 [0.02]	0.4 [0.02]	0.6 N-m	6 N-m/rad	Glass-fiber reinforced resin
	GJ-6D	\$7.75	TRD-S (6mm)	6mm	6mm	15 [0.59]	22 [0.87]	5.2 [0.20]	3 [0.12]	M3 set screw	6°	0.5 [0.02]	0.12 [0.005]	0.8 N-m	10 N-m/rad	
	GJ-8D	\$7.75	TRD-N/NA (8mm)	8mm	8mm	19 [0.75]	24 [0.94]	6.8 [0.27]	3.5 [0.14]	M4 set screw	5°	0.5 [0.02]	0.4 [0.016]	1.5 N-m	20 N-m/rad	
	GJ-10D	\$10.00	TRD-GK (10 mm)	10 mm	10 mm	22 [0.87]	26 [1.02]	7.1 [0.28]	4 [0.16]	M4 set screw	5°	0.5 [0.02]	0.12 [0.005]	2.0 N-m	32 N-m/rad	
Fiberglass (SAE)	GJ-635D	\$11.00	TRDA-2E (0.25 in)	0.25 in	0.25 in	15 [0.59]	22 [0.87]	5.2 [0.20]	3 [0.12]	M3 set screw	5°	0.5 [0.02]	0.12 [0.005]	0.8 N-m	10 N-m/rad	Glass-fiber reinforced resin
	GJK-953D	\$16.50	TRDA-20/25 (0.375 in)	0.375 in	0.375 in	25 [0.98]	32 [1.26]	7.3 [0.29]	3.5 [0.14]	M4 set screw	5°	0.5 [0.02]	0.12 [0.005]	2.0 N-m	32 N-m/rad	
Polymer (SAE)	STP-MTRA-SC-1412	\$20.50	TRDA-2E (0.25 in)	0.25 in	0.50 in	25 [0.98]	38 [1.50]	9.9 [0.39]	5.4 [0.21]	M3 cap screw	5°	0.3 [0.01]	0.12 [0.005]	3.7 N-m	0.36 °/lb-in	Engineered polymer
	STP-MTRA-SC-3812	\$20.50	TRDA-20/25 (0.375 in)	0.375 in	0.50 in	25 [0.98]	38 [1.50]	9.9 [0.39]	5.4 [0.21]	M3 cap screw	5°	0.3 [0.01]	0.12 [0.005]	3.7 N-m	0.36 °/lb-in	
Aluminum (metric)	ARM-075-5-4D	\$30.00	TRD-MX (4mm)	4mm	5mm	19.1 [0.75]	19.1 [0.75]	4.6 [0.18]	2.4 [0.09]	M3 set screw	5°	0.25 [0.01]	0.25 [0.01]	2.3 N-m	8.2 N-m/rad	Aluminum alloy
	RU-075D	\$47.00	TRD-S (6mm)	6mm	6mm	19.1 [0.75]	19.1 [0.75]	4.6 [0.18]	2.4 [0.09]	M3 set screw	5°	0.25 [0.01]	0.12 [0.005]	1.0 N-m	8.2 N-m/rad	
	JU-100D	\$43.00	TRD-N/NA (8mm)	8mm	8mm	25.4 [1.00]	25.4 [1.00]	6.6 [0.26]	3.8 [0.15]	M5 set screw	5°	0.25 [0.01]	0.25 [0.01]	1.6 N-m	14.3 N-m/rad	
	RU-100D	\$46.00	TRD-GK (10 mm)	10 mm	10 mm	25.4 [1.00]	25.4 [1.00]	6.6 [0.26]	3.8 [0.15]	M5 set screw	5°	0.25 [0.01]	0.12 [0.005]	1.6 N-m	14.3 N-m/rad	
Aluminum (metric-to-SAE)	ML13P-4-476D	\$30.00	TRD-MX (4mm)	4mm	0.1875 in	13 [0.51]	19 [0.75]	5.5 [0.22]	2.5 [0.10]	M2 set screw	5°	0.4 [0.02]	0.2 [0.01]	0.25 N-m	44 N-m/rad	Aluminum alloy (Bent plate; Polyimide)
	ML16P-4-635D	\$30.00	TRD-MX (4mm) TRDA-2E (0.25 in)	4mm	0.25 in	16 [0.63]	23 [0.91]	7 [0.28]	3 [0.12]	M3 set screw	5°	0.6 [0.02]	0.3 [0.01]	0.4 N-m	70 N-m/rad	
	MCGL16-6-635	\$20.50	TRD-S (6mm) TRDA-2E (0.25 in)	6mm	0.25 in	16 [0.63]	23.2 [0.91]	7 [0.28]	3 [0.12]	M3 set screw	3.5°	0.3 [0.01]	0.3 [0.01]	0.4 N-m	70 N-m/rad	
	MCGL20-8-635	\$29.50	TRD-N/NA (8mm) TRDA-2E (0.25 in)	8mm	0.25 in	20 [0.79]	26 [1.02]	7.5 [0.30]	3.7 [0.15]	M3 set screw	3.5°	0.3 [0.01]	0.4 [0.02]	0.6 N-m	130 N-m/rad	
	MCGL20-8-952	\$29.50	TRD-N/NA (8mm) TRDA-20/25 (0.375 in)	8mm	0.375 in	20 [0.79]	26 [1.02]	7.5 [0.30]	3.7 [0.15]	M3 set screw	3.5°	0.3 [0.01]	0.4 [0.02]	0.6 N-m	130 N-m/rad	
	MCGL25-10-635	\$34.00	TRD-GK (10 mm) TRDA-2E (0.25 in)	10 mm	0.25 in	25 [0.98]	30.2 [1.19]	9 [0.35]	4 [0.16]	M4 set screw	3.5°	0.3 [0.01]	0.5 [0.02]	1.4 N-m	240 N-m/rad	
	MCGL25-10-952	\$34.00	TRD-GK (10 mm) TRDA-20/25 (0.375 in)	10 mm	0.375 in	25 [0.98]	30.2 [1.19]	9 [0.35]	4 [0.16]	M4 set screw	3.5°	0.3 [0.01]	0.5 [0.02]	1.4 N-m	240 N-m/rad	
Aluminum (SAE)	ARM-075-635-635D	\$28.00	TRDA-2E (0.25 in)	0.25 in	0.25 in	19.1 [0.75]	19.1 [0.75]	4.6 [0.18]	2.4 [0.09]	M3 set screw	5°	0.25 [0.01]	0.25 [0.01]	1.0 N-m	8.2 N-m/rad	Aluminum alloy
	ARM-100-9525-9525D	\$30.00	TRDA-20/25 (0.375 in)	0.375 in	0.375 in	25.4 [1.00]	25.4 [1.00]	6.6 [0.26]	3.8 [0.15]	M5 set screw	5°	0.25 [0.01]	0.25 [0.01]	1.6 N-m	14.3 N-m/rad	

* mm ÷ 25.4 = inches

Encoder Accessories – Couplings

Encoder Couplings – Dimensions

GJ-xxD Fiberglass Couplings (metric) & GJx-xxxD Fiberglass Couplings (SAE)

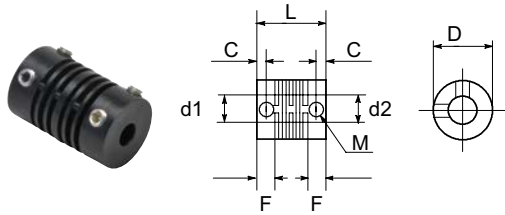

STP-MTRA-SC-xxxx Polymer Couplings

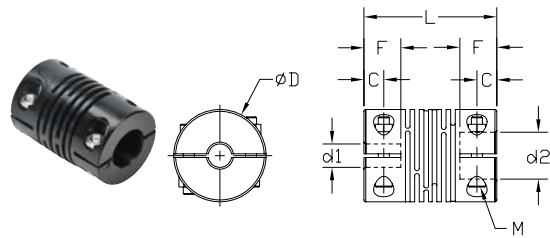

ARM-xxxxxD Aluminum Couplings (metric & SAE)

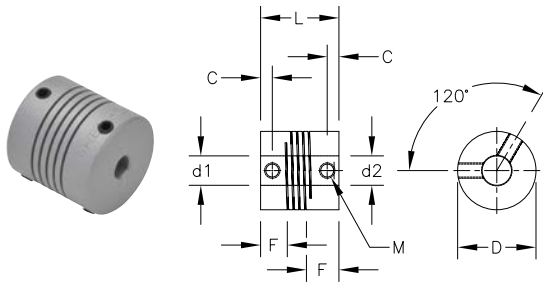

MCGLxx Aluminum Couplings & ML1xP-4-xxxD Aluminum Couplings

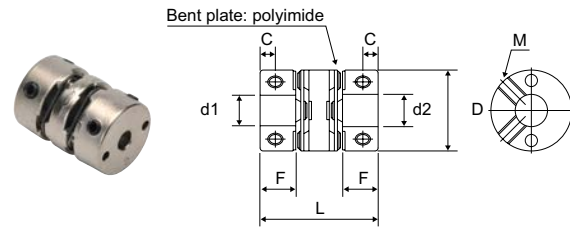

RU-075D, RU-100D, and JU-100D Aluminum Couplings

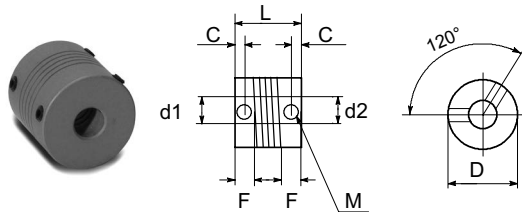

Great Encoder Selection at Great Prices



Koyo

Duty	Family	Size	Encoder diameter	Shaft diameter	Solid or Hollow Shaft	Operating Voltage (VDC) and Electrical Output*	IP Rating	Max Radial Load (N)	Max Axial Load (N)	Available resolutions	
Incremental	Light Duty	TRD-MX	10	25mm	4mm	solid	5V Line Driver or 5-12V OC or 12-24V OC	IP50	10	5	100, 360, 500, 1000, 1024
		TRDA-2E	15	1.5"	1/4"	solid	5V Line Driver or 12-24V OC	IP50	30	20	100, 360, 500, 1000, 1024, 2500
		TRD-S	15	38mm	6mm	solid	5V Line Driver or 5-12V OC or 12-24V OC	IP40	20	10	100, 200, 250, 300, 360, 400, 500, 600, 800, 1000, 1024, 1200, 2000, 2500
		TRD-SH	15	38mm	8mm	hollow	5V Line Driver or 5-12V OC or 12-24V OC	IP40	20	10	100, 200, 250, 300, 360, 400, 500, 600, 800, 1000, 1024, 1200, 2000, 2500
	Medium Duty	TRDA-20	20	2"	3/8"	solid	5V Line Driver or 5-30V P/P	IP50	50	30	100, 360, 500, 1000, 1024, 2500
		TRDA-25	25 (w/size 20 body)	2.5" flange (w/ 2.0" body)	3/8"	solid	5V Line Driver or 5-30V P/P	IP65	50	30	100, 360, 500, 1000, 1024, 2500
		TRD-N	20	50mm	8mm	solid	5V Line Driver or 5-30V P/P	IP65	50	30	3, 4, 5, 10, 30, 40, 50, 60, 100, 120, 200, 240, 250, 300, 360, 400, 480, 500, 600, 750, 1000, 1024, 1200, 2000, 2500, 3000, 3600, 5000
		TRD-NH	20	50mm	8mm	hollow	5V Line Driver or 5-30V P/P	IP65	50	30	3, 4, 5, 10, 30, 40, 50, 60, 100, 120, 200, 240, 250, 300, 360, 400, 480, 500, 600, 750, 1000, 1024, 1200, 2000, 2500, 3000, 3600, 5000
	Heavy Duty	TRD-GK	30	78mm	10mm	solid	10-30V P/P	IP65	100	50	30, 100, 120, 200, 240, 250, 300, 360, 400, 500, 600, 800, 1000, 1200, 1500, 1800, 2000, 2500, 3600, 5000
		TRD-NA	20	50mm	8mm	solid	10-30V OC	IP65	50	30	32, 64, 128, 180, 256, 360, 512, 720, 1024, 2048 (Gray code)
Medium Duty Absolute	TRD-NA	20	50mm	8mm	solid	10-30V OC	IP65	50	30	32, 64, 128, 180, 256, 360, 512, 720, 1024, 2048 (Gray code)	

All our encoders feature an integral 2m cable except for the TRDA-25 series which has an MS connector

*Operating Voltage and Electrical Output:
 • LD = Line Driver (all Line Drivers require 5VDC supply)
 • OC = NPN Open Collector (at Operating Voltage)
 • P/P = Push Pull or Totem Pole (at Operating Voltage)

Accessories

Couplings

A variety of couplings - metric-to-metric, inch-to-inch (SAE - SAE), and metric-to-inch are in stock, ready to ship.



Flanges

A collection of flanges that ease encoder mounting. Several models are available with round flanges, square flanges and miscellaneous mounting options.



Mounting brackets

Simplify your installation with a ready-to-use right-angle mounting bracket for light, medium and heavy-duty encoders



Cables

For encoders that require a connector cable, we have cables in stock, priced right and ready to ship.

