

GSD6 Series DC Drives

GSD6 Introduction



GSD6-240-15C

GSD6 Series DC Drives

Motor Rating Range @ 115/230 VAC_{IN}

1/8 – 3 hp

Overview

The reliable, versatile, and economical GSD6 DC drive is the most fully-featured IronHorse analog DC drive.

It provides many standard features typically offered as options by other DC drives.

By combining advanced engineering design, quality component selection, and rigorous quality control, the GSD6 DC drive offers an excellent off-the-shelf SCR control device. Its dependable, time-proven circuitry offers performance characteristics previously available only in more costly drives.

Features

- Dual input voltage 115/230 VAC, 50/60 Hz via slide selector switch
- Adjustable horsepower settings
- Barrier terminal strip
- Packaged bridge supply (full wave)
- 1% speed regulation with armature voltage feedback ($\pm 1/2\%$ with tach feedback)
- Adjustable minimum speed
- Adjustable maximum speed
- Adjustable IR compensation
- Adjustable linear acceleration
- Adjustable linear deceleration
- Adjustable current limit
- Line voltage compensation
- 5k Ω speed potentiometer with leads, dial, and knob included
- 50:1 speed range
- Overload capacity: 200% for one minute
- Transient voltage protection
- Voltage following mode or DC tachometer follower by supplying ungrounded analog input signal
- DC tachometer feedback (jumper selectable)
- Inhibit circuit – permits start and stop without breaking AC lines
- Shunt field supply provided
- AC line fuses
- +12 VDC, 12mA power supply, user accessible

Accessories

- Replacement speed potentiometer kit
- Digital potentiometer
- Analog current input card

Detailed descriptions and specifications for GSD accessories are available in the “GSD Series DC Drives Accessories” section.

Typical Applications

- Auger feeders
- Automated door actuators
- Commercial cooking equipment
- Commercial lift
- Food production
- Industrial pumping systems
- Measurement instruments
- Miniature lathes and mills
- Packaging / material-handling equipment
- Printing and labeling machines
- Small shop machine tools
- Spray / print reciprocating head

GSD6 Series DC Drives

GSD6 Selection and Specifications

GSD6 Series DC Drives – Selection & Specifications		
Model	GSD6-240-15C	
Price	\$366.00	
Package Configuration	Open frame	
Power Quality Form Factor	1.4	
Input Voltage (@50/60Hz)	115/230 VAC ±10%	
Output Voltage	0–90 @ 115 VAC INPUT / 0–180 VDC @ 230 VAC input	
Shunt Field Voltage	100VDC @ 115VAC input ; 200VDC @ 230VAC input ; (1.5A max)	
Motor Rating (hp)	1/8 – 1.5 hp @ 90VDC ; 1/4 – 3 hp @ 180VDC	
Output Current (continuous)	15A (DC)	
Current Overload Capacity	200% for 60s	
Current Limit (adjustable)	2–30A (DC)	
Transient Protection	Metal Oxide Varistor (MOV)	
I.R. Compensation	Adjustable	
Speed Adjustment	Potentiometer	5k Ω 2W potentiometer
	Current	4–20mA with option GSDA-AI-A
	Voltage	n/a
Speed Range	50:1	
Speed Regulation	±1% of base speed	
Maximum Speed	Adjustable from 60% to 120% of base speed	
Minimum Speed	Linear ramp 0–30% of adjustable maximum speed	
Acceleration	Linear ramp adjustable 0.3–12s	
Deceleration	Adjustable 0.6–12s	
Dynamic Braking	No	
Plugging Capability **	No	
Electrical Connections	Barrier-type terminal strip; 26–12 AWG	
Fusing	(2) 20A fuses included (Bussman ABC-20 or Littelfuse 314020 ceramic fuses or equivalent)	
Operating Temperature	-10 to 45 °C [14 to 113 °F]	
Thermal Protection	Not available	
Mounting Orientation	Can be mounted in any orientation	
Corrosive Gases	NOT compatible with any corrosive gases	
Weight	40 oz [1134g]	
Agency Approvals	RoHS	
Optional Accessories*		
Replacement Potentiometer	GSDA-5K	
Digital Potentiometer	GSDA-DP	
Analog Current Input Card	GSDA-AI-A	
* For accessories details, refer to the "GSD Series DC Drives Accessories" section.		
** Plugging is a method of rapidly changing motor direction by reversing motor armature polarity, while the motor is still running.		

GSD6 Series DC Drives

GSD6 Wiring Diagrams

GSD6-240-15C Basic Wiring Diagram – (refer to User Manual for more detailed wiring information)

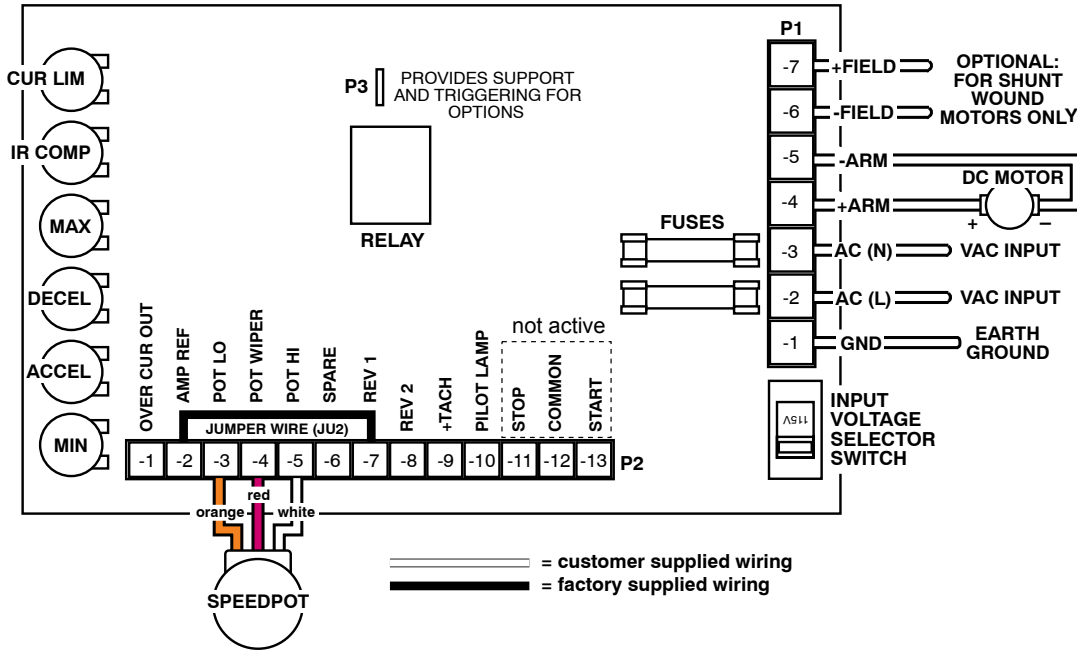

GSD6 Dimensions – dimensions = in [mm]

GSD6-240-15C Dimensions

