

IronHorse® Permanent-Magnet DC Motors (SCR Rated) Model Overview



MTPM-P10-1JK43



MTPM-P25-1JK44



MTPM-P33-1L18



MTPM-P75-1L18



MTPM-1P5-1M18

IronHorse motors are manufactured by leading motor suppliers with over 20 and 45 years experience delivering high-quality motors to the demanding U.S. market. Our suppliers test the motors during production and after final assembly. This is how we can stand behind our IronHorse motors with a **two-year warranty** (motors 1/3 hp and above only; motors 1/4 hp and less have a one-year warranty).

IronHorse DC motors are designed for use on unfiltered SCR (Thyristor) type and PWM (pulse width modulated) type DC adjustable speed drives, and on across-the-line DC controls.

The IronHorse line of DC motors features:

- Replacement brush sets
- Simple two-lead connection
- Class F insulation

Features for Small-Frame Motors 1/4 hp and Under

- Available models accommodate 12VDC, 24VDC, 90VDC (110VAC DC drive), and 180VDC (230VAC DC drive)
- Rated for SCR drives
- TENV enclosure
- IP40 environmental rating
- Class F insulation
- High energy ceramic magnets
- Double shielded ball bearings
- Dynamically balanced armature
- Reversible design
- 18-inch leads, or junction boxes with 8-inch leads
- Externally replaceable brushes
- Can be mounted in any orientation
- Not intended for DC power generation
- UL recognized (E365956), CSA certified (259724), RoHS

Features for Motors 1/3 hp and Above

- Input power of 115 or 230 volts rectified AC can be used with an appropriate SCR drive
- Linear speed/torque characteristics over entire speed range
- High starting torque for heavy load applications
- Capable of dynamic braking for faster stops
- Available in TENV or TEFC housings, depending on model
- NEMA 56C flange mount
- Rolled steel shell frame / cast aluminum end bell
- Removable base (0.33–2 hp)
- STABLE motor slide bases for adjustable mounting of NEMA motors from 56–449T
- Space-saving design
- Large replaceable brushes for longer brush life
- Easy access to DC motor brushes (DC motors ship with one set of brushes installed and one set of spare brushes in the box)
- Large easy-to-wire junction box with rubber gasket and six-inch leads
- Heavy duty oversized ball bearings
- High tensile strength steel shaft
- Large easy to read nameplate
- Electrically reversible
- Not intended for DC power generation
- Service Factor: 1.0
- Two year warranty
- cCSA_{US} certified (247070), CE, RoHS

Applications

- Conveyors
- Turntables
- Where adjustable speed and constant torque are required
- When dynamic braking and reversing capabilities are needed

IronHorse® DC Motors

MTPM Small-Frame Permanent Magnet DC Motors – 1/31 hp – 1/4 hp



MTPM-P10-1JK43
with flying leads



MTPM-P25-1JK44
with junction box

Selection and Specifications

Motor Specifications – MTPM Series Small-Frame Permanent Magnet DC Motors												
Part Number	Price	Voltage (VDC)	HP	Speed (rpm)	F/L Torque (oz-in)	F/L Current (A)	Shaft Dia (in)	Pilot Shaft (in)	Overhung Load (lb)	Axial/Thrust Load (lb)	Wiring Type	Weight (lb)
MTPM-P10-1JK43	\$77.00	12 24	1/20 1/10	1746 4252	28	4.83	0.3125	1.00	85	70	flying leads	2.75
MTPM-P13-1JK42	\$84.00	12 24	1/17 1/8	1825 4224	32	5.39	0.3125					3.25
MTPM-P17-1JK43	\$113.00	12 24	1/13 1/6	1841 4290	42	7.54	0.50	2.02	130	150	junction box	5.3
MTPM-P25-1JK40	\$137.00	12 24	1/6 1/4	1732 3996	96 80	14.3 12.2	0.50					7.8
MTPM-P25-1JK44	\$137.00	12 24	1/5 1/4	1854 4375	113 70	18.1 11.9	0.50					9
MTPM-P03-1L18	\$82.00	90	1/31	1797	18	0.39	0.3125	1.00	85	70	flying leads	2.75
MTPM-P04-1L17	\$86.00		1/26	1749	22	0.46	0.3125					3.25
MTPM-P05-1L19	\$113.00		1/19	1917	28	0.68	0.50	2.02	130	150	junction box	5.3
MTPM-P13-1L19	\$131.00		1/8	1917	73	1.4	0.50					7.8
MTPM-P14-1L19	\$143.00		1/7	1740	86	1.61	0.50					9
MTPM-P07-1M24	\$118.00	180	1/15	2440	28	0.42	0.50					5.3
MTPM-P13-1M19	\$143.00		1/8	1865	73	0.73	0.50	7.8				
MTPM-P14-1M18	\$143.00		1/7	1828	84	0.83	0.50	9				



MTPM-BRUSH-x



MTGA-KIT-1

Replacement Parts

Replacement Parts for MTPM Series Small-Frame Permanent Magnet DC Motors *			
Part Number	Price	Description	For Motors MTPM-
MTPM-BRUSH-4	\$30.00	DC motor brushes, replacement, for 1/4 hp 24VDC MTPM series permanent magnet DC motors. Package includes one set of 2 brushes and 2 brush caps.	P25-1JK40, P25-1JK44
MTPM-BRUSH-5	\$22.50	DC motor brushes, replacement, for 24VDC MTPM series permanent magnet DC motors 1/6 hp and smaller. Package includes one set of 2 brushes and 2 brush caps.	P10-1JK43, P13-1JK42, P17-1JK43
MTPM-BRUSH-6	\$25.50	DC motor brushes, replacement, for 1/7 or 1/8 hp 90VDC or 180VDC MTPM series permanent magnet DC motors. Package includes one set of 2 brushes and 2 brush caps.	P13-1L19, P14-1L19, P13-1M19, P14-1M18
MTPM-BRUSH-7	\$20.50	DC motor brushes, replacement, for 90VDC or 180VDC MTPM series permanent magnet DC motors 1/10 hp and smaller. Package includes one set of 2 brushes and 2 brush caps.	P03-1L18, P04-1L17, P05-1L19, P07-1M24
MTGA-KIT-1	\$39.50	DC motor spare parts kit, for certain MTPM series permanent magnet DC motors as listed. Includes: two metal brush cap covers, one terminal box, one 1/8 (0.125 inch) shaft key and one 3/16 (0.187 inch) shaft key.	P05-1L19, P13-1L19, P14-1L19, P17-1JK43, P25-1JK40, P25-1JK44, Pxx-1Mxx

* These replacement parts also fit many AutomationDirect DC gearmotors. Refer to the Gearmotors section for gearmotor application information.

IronHorse® DC Motors

MTPM Small-Frame Permanent Magnet DC Motors – 1/31 hp – 1/4 hp

Dimensions (in [mm])

Model Numbers (MTPM-): P03-1L18, P04-1L17, P10-1JK43, P13-1JK42

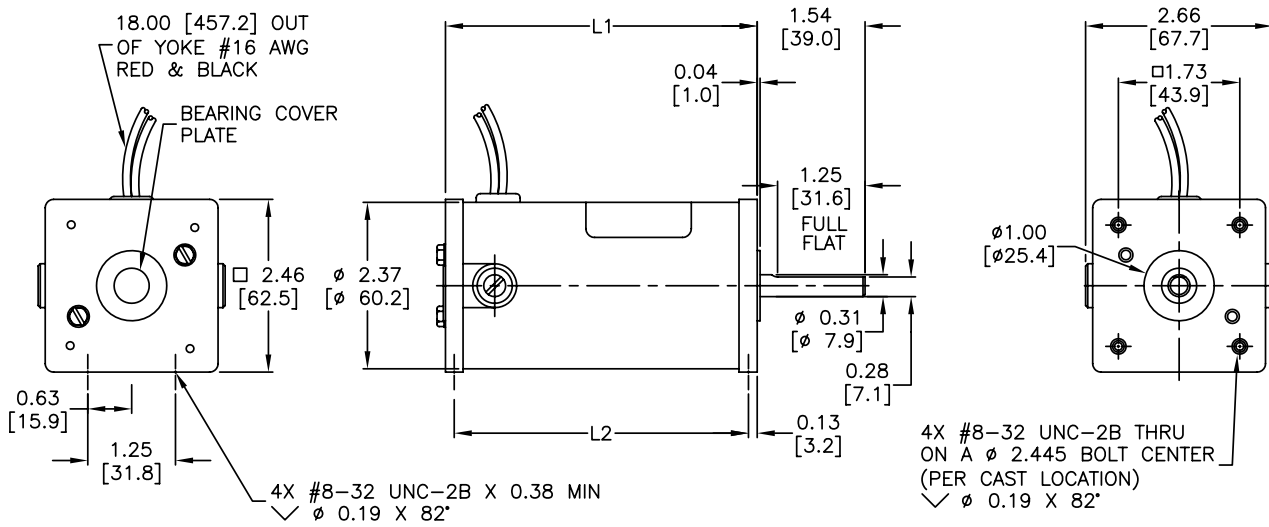

MTPM-	L1	L2
P03-1L18, P10-1JK34	4.44 [112.8]	4.16 [105.5]
P04-1L17, P13-1JK42	4.94 [125.5]	4.69 [119.1]

Model Numbers (MTPM-): P05-1L19, P07-1M24, P13-1L19, P13-1M19, P14-1L19, P14-1M18, P17-1JK43, P25-1JK40, P25-1JK44

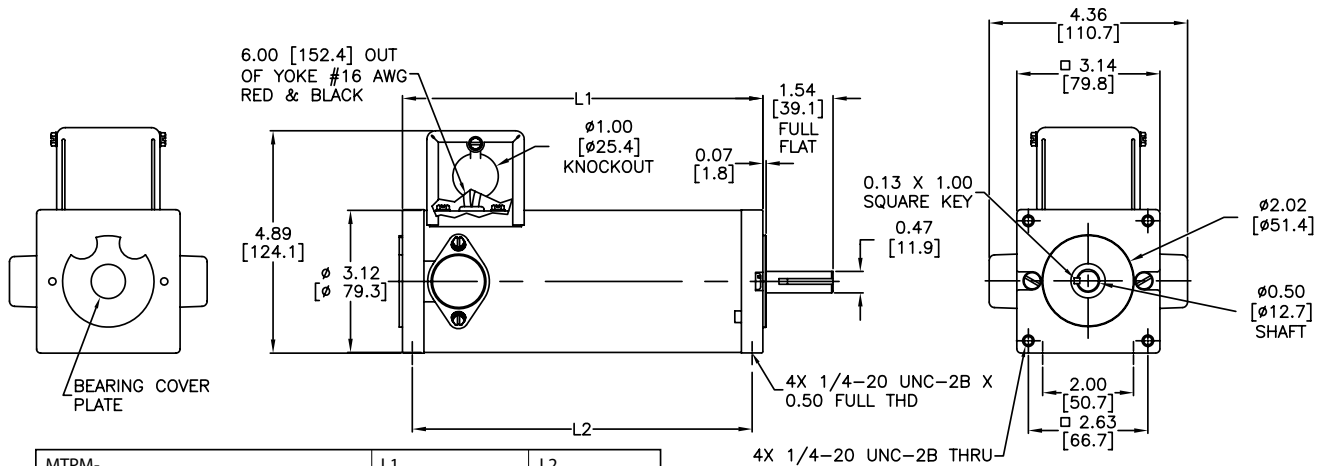

MTPM-	L1	L2
P05-1L19, P07-1M24, P17-1JK43	4.92 [125.0]	4.56 [115.8]
P13-1L19, P13-1M19, P25-1JK40	6.92 [175.8]	6.46 [164.1]
P14-1L19, P14-1M18, P25-1JK44	7.92 [201.2]	7.46 [189.5]

IronHorse® DC Motors

56C Frame TEFC/TENV Motors – DC – 0.33 to 2 hp



Motor Specifications – DC 56C Frame Motors – 1800 RPM									
Part Number	Price	HP	Base RPM	Armature Voltage	Housing	NEMA Frame	Service Factor	F.L. Amps	Weight (lb)
MTPM-P33-1L18	\$144.00	1/3	1800	90 VDC	TENV	56C flange mount	1.0	3.5	17.70
MTPM-P50-1L18	\$185.00	1/2						5.2	20.74
MTPM-P75-1L18	\$210.00	3/4			7.8			25.30	
MTPM-001-1L18	\$233.00	1			10.4			28.36	
MTPM-1P5-1L18	\$253.00	1-1/2			15.4			34.97	
MTPM-P33-1M18	\$143.00	1/3		180 VDC	TENV			1.75	17.60
MTPM-P50-1M18	\$184.00	1/2						2.6	20.74
MTPM-P75-1M18	\$210.00	3/4			3.9			25.58	
MTPM-001-1M18	\$233.00	1			5.2			28.32	
MTPM-1P5-1M18	\$253.00	1-1/2			7.7			35.70	
MTPM-002-1M18	\$402.00	2	9.8	61.95					

Note: Please review the AutomationDirect Terms & Conditions for warranty and service on this product.

Performance Data – DC 56C Frame Motors – 1800 RPM																													
Part Number	HP	Armature Voltage	Torque (lb-ft)	Form Factor *	Ambient Temp.	Insulation Class	Ball Bearings		Mounting	Wire / Housing	Shaft	Constant Torque Speed Range	Overall Speed Range	Base / Type	Paint Color	Rotor Inertia (kg/m ²)	Efficiency (%)												
			Full Load				DE Bearing	ODE Bearing																					
MTPM-P33-1L18	1/3	90 VDC	0.97	1.35	40°C (104°F)	F	6203	6203	Top Mounted	Junction Box	Keyed	90-1800 RPM	0-2000 RPM	Rigid Removable	Gray	0.01956	79												
MTPM-P50-1L18	1/2		1.46													0.02365	80												
MTPM-P75-1L18	3/4		2.19													0.02795													
MTPM-001-1L18	1		2.92													0.03225													
MTPM-1P5-1L18	1-1/2		4.38													0.04945	81												
MTPM-P33-1M18	1/3	180 VDC	0.97													1.35	40°C (104°F)	F	6203	6203	Top Mounted	Junction Box	Keyed	90-1800 RPM	0-2000 RPM	Rigid Removable	Gray	0.01956	79
MTPM-P50-1M18	1/2		1.46																									0.02365	80
MTPM-P75-1M18	3/4		2.19																									0.02795	
MTPM-001-1M18	1		2.92																									0.03225	
MTPM-1P5-1M18	1-1/2		4.38																									0.04945	81
MTPM-002-1M18	2	5.84	0.09675	85																									

* See additional information in Form Factor Table.

Form Factor

The voltage used to power a permanent magnet (PM) DC motor is not pure DC; it is derived by rectifying a supplied AC voltage. The resulting DC voltage has a ripple that is related to the frequency of the AC input.

Form factor is the ratio of I_{rms} to I_{dc} , and it indicates how close the driving voltage is to pure DC. The form factor for a DC battery is 1.0. The higher the form factor is above 1.0, the more it deviates from pure DC. The Form Factor Table shows examples of commonly used voltages.

Form factor should not exceed 1.40 for continuous operation. Half wave rectification is not recommended, as it drastically increases form factor.

Operating IronHorse PMDC motors with DC voltages with form factors higher than 1.40 can result in premature brush failure and excessive motor heating.

Form Factor Table	
Form Factor	DC Voltage Source
1.0	Battery (pure DC)
1.05 *	Pulse width modulation (PWM)
1.40 **	Full wave rectification (single phase)
1.9 ***	Half wave rectification (single phase) **

* All DC-input IronHorse GSD series DC drives are 1.05. IronHorse AC-input GSD5 DC drive is 1.05.
 ** Single phase full wave rectification is the most common form of DC drive in 0.33-2 hp range. All IronHorse GSD series DC drives are 1.40 or better.
 *** Not Recommended.

IronHorse® DC Motors

56C Frame TENV DC Motors – 0.33 to 0.5 hp – Dimensions

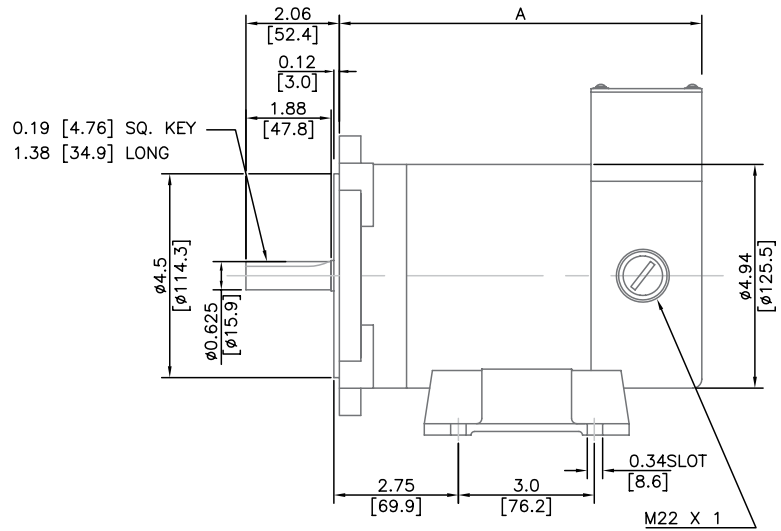
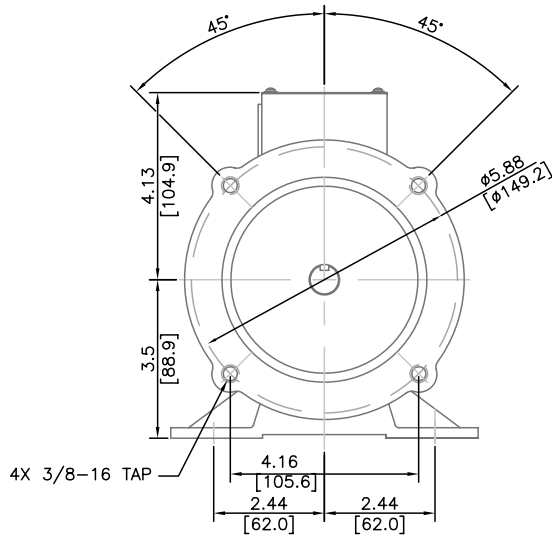

A = 8.0"	[203.2]	- 0.33 HP, 90VDC, 1800RPM
A = 8.0"	[203.2]	- 0.33 HP, 180VDC, 1800RPM
A = 8.88"	[225.5]	- 0.50 HP, 90VDC, 1800RPM
A = 8.88"	[225.5]	- 0.50 HP, 180VDC, 1800RPM

UNITS: INCHES [mm]

56C Frame TEFC DC Motors - 0.75 to 1.5 hp - Dimensions

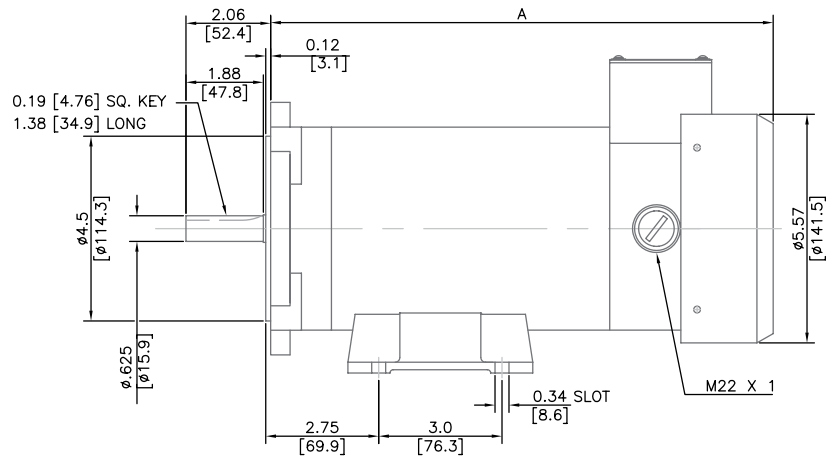
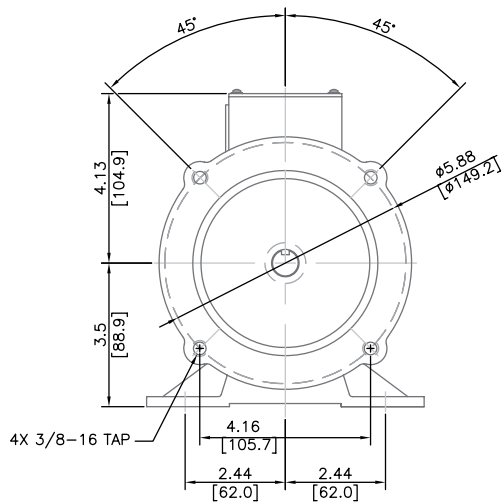

A = 11.45"	[290.8]	- .75 HP, 90VDC, 1800RPM
A = 11.45"	[290.8]	- .75 HP, 180VDC, 1800RPM
A = 12.24"	[311.0]	- 1 HP, 90VDC, 1800RPM
A = 12.24"	[311.0]	- 1 HP, 180VDC, 1800RPM
A = 14.39"	[365.5]	- 1.5 HP, 90VDC, 1800RPM
A = 14.39"	[365.5]	- 1.5 HP, 180VDC, 1800RPM

UNITS: INCHES [mm]

IronHorse® DC Motors

56C Frame TEFC DC Motors – 2 hp – Dimensions

Dimensions = inches [mm]

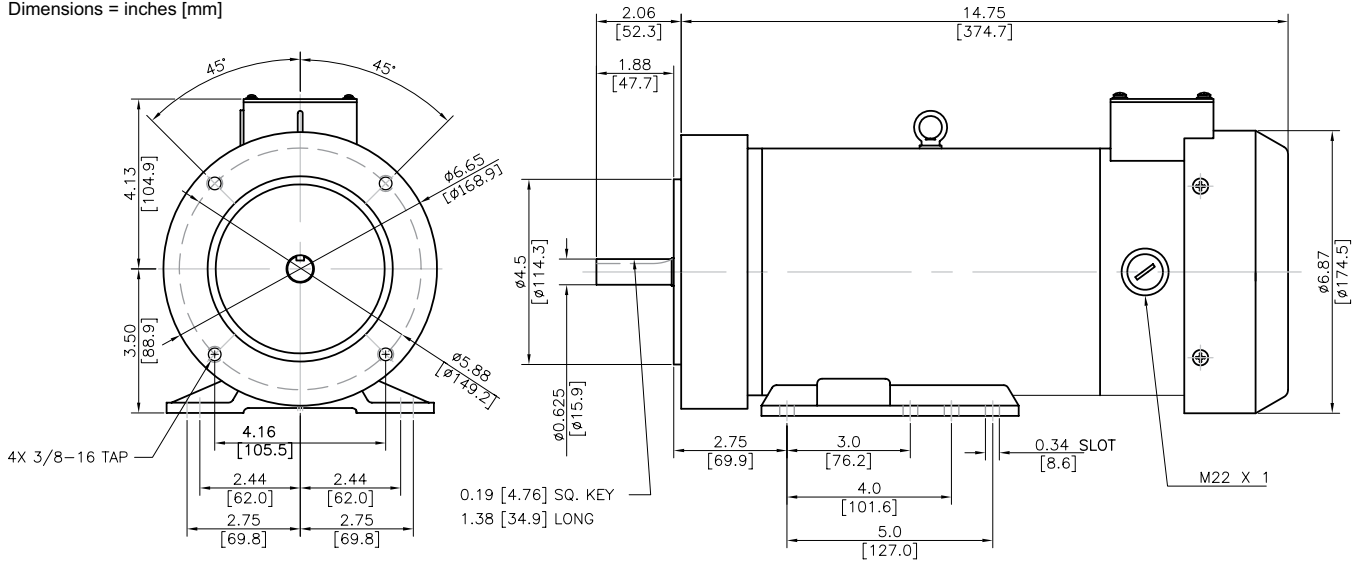

56C Frame Motors – DC – 0.33 to 2 hp – Accessories

DC motor brushes



Brushes commutate the incoming current in a DC motor. All IronHorse PMDC motors are shipped with a set of brushes in the motor. An extra set of brushes is included in the box. The brushes below can be ordered for spare.

IronHorse DC brushes should be changed at a maximum interval of 2500 hours motor runtime. When changing brushes, always change them as a set (never change only one brush).

DC Motor Accessories							
Part Number	Price	Description	Applicable Motor Type	Rated Voltage	Motor HP	Brush Materials	Dimension L x W x H
MTPM-BRUSH-1	\$9.50	Brushes with springs, one set of 2	IronHorse MTPM	90 VDC 180 VDC	0.33–1.5 hp	Resin class Graphite	0.75 in x 0.27 in x 0.70 in 19 mm x 6.9 mm x 18 mm
MTPM-BRUSH-2	\$12.00	Brushes with springs, one set of 2		180 VDC	2hp		0.71 in x 0.49 in x 0.70 in 18 mm x 12 mm x 18 mm
MTPM-BRUSH-3	\$11.00	Brushes with springs, one set of 2		90 VDC	1.5 hp		0.73 in x 0.35 in x 0.63 in 19 mm x 8.9 mm x 16 mm

All IronHorse 56C-frame DC motors ship with one set of brushes installed and one extra set in the box.