

IEC Limit Switches

ABP series double insulated limit switches

- Featuring an electrically isolated PBT body for corrosive environments
- Single conduit openings in 1/2" NPT or PG13.5
- Conduit openings splined actuator shaft allows very fine adjustment of switch to fit all applications
- Choose from eight different actuators including roller levers, plungers, and wobble sticks

ABP Series									
Part Number	Price	Actuator Type	Number of Conduit Holes	Conduit Threads	Max. Actuation Speed (m/s)	Min. Actuation Force (N) Torque (N·m)	Min. Positive Opening Force (N) Torque (N·m)	Dimensions: Body / Head	Photo
ABP1H14Z11	\$29.50	Galvanized steel plunger	One	PG13.5	0.5	14N	40N	Figures 3, 5	A
ABP2H14Z11	\$30.00		One	1/2" NPT	0.5	14N	40N	Figures 3, 5	A
ABP1H19Z11	\$29.50	Galvanized steel plunger with roller	One	PG13.5	0.5	14N	40N	Figures 3, 6	B
ABP2H19Z11	\$30.00		One	1/2" NPT	0.5	14N	40N	Figures 3, 6	B
ABP1H35Z11	\$30.00	One-way lever with polyamide roller	One	PG13.5	1.0	8N	30N	Figures 3, 7	C
ABP2H35Z11	\$30.00		One	1/2" NPT	1.0	8N	30N	Figures 3, 7	C
ABP1H41Z11	\$29.50	Side rotary lever with polyamide roller	One	PG13.5	1.5	0.15 N·m	0.30 N·m	Figures 3, 8	D
ABP2H41Z11	\$30.00		One	1/2" NPT	1.5	0.15 N·m	0.30 N·m	Figures 3, 8	D
ABP1H51Z11	\$30.00	Side rotary adjustable lever with polyamide roller	One	PG13.5	1.5	0.15 N·m	0.30 N·m	Figures 3, 9	E
ABP2H51Z11	\$30.00		One	1/2" NPT	1.5	0.15 N·m	0.30 N·m	Figures 3, 9	E
ABP1H71Z11	\$30.00	Side rotary with stainless steel rod	One	PG13.5	1.5	0.15 N·m	0.30 N·m	Figures 3, 10	F
ABP2H71Z11	\$30.00		One	1/2" NPT	1.5	0.15 N·m	0.30 N·m	Figures 3, 10	F
ABP1H92Z11	\$30.00	Wobble lever w/ polyamide tip stainless steel spring	One	PG13.5	1.0	0.18 N·m	-	Figures 3, 11	G
ABP2H92Z11	\$30.00		One	1/2" NPT	1.0	0.18 N·m	-	Figures 3, 11	G
ABP1H93Z11	\$30.00	Wobble lever w/ stainless steel spring	One	PG13.5	1.0	0.18 N·m	-	Figures 3, 12	H
ABP2H93Z11	\$30.00		One	1/2" NPT	1.0	0.18 N·m	-	Figures 3, 12	H



IEC Limit Switches Accessories

Replacement contact blocks

Easily-installed replacement contact blocks fit both heavy-duty IEC and double-insulated limit switches, including mini-DIN models.

Note: Limit switches come standard with snap-action contacts (AGZ11-SWITCH.) To replace contact block, remove limit switch cover. Carefully remove old contact block and install replacement. Contact blocks are supplied with an adapter to fit into larger ABM and ABP switches. Remove this adapter when installing contacts in mini-DIN AAP models.



Replacement Contact Blocks			
Part Number	Price	Contact Type	Action
AGZ11-SWITCH	\$5.75	Snap-action 1 N.C. and N.O.	3ms change-over time
AGZ02-SWITCH	\$5.50	Snap-action 2 N.C.	3ms change-over time
AGX11-SWITCH	\$5.50	Slow-action 1 N.C. and 1 N.O.	Break before make
AGY11-SWITCH	\$5.50	Slow-action overlay 1 N.C. and 1 N.O.	Make before break
AGW02-SWITCH	\$6.00	Slow-action delay 2 N.C.	Simultaneous
AGW20-SWITCH	\$4.00	Slow-action overlay 2 N.O.	Simultaneous

Additional lever arms, spare parts and accessories for ABM series

Additional Lever Arms/Spare Parts and Accessories			
Part Number	Price	Dimensions	Actuator Type
AGE42-LEVER	\$5.50	Figure 8	Lever with stainless steel roller for E42 models (replacement lever)
AGE44-LEVER	\$5.50	Figure 13	Lever with 50mm diameter rubber roller (fits E42 models)
AGE52-LEVER	\$6.75	Figure 9	Lever with stainless steel roller for E52 models (replacement lever)
AGE54-LEVER	\$6.75	Figure 14	Lever with 50mm diameter rubber roller (fits E52 models)

Note: See the Bar Charts page of this section for more information.



Replacement actuator levers for heavy-duty IEC models

Easily-replaceable actuators for E42 and E52 model limit switches.

Note: These models have an E42 or E52 in the part number, for example, ABM1E42Z11.

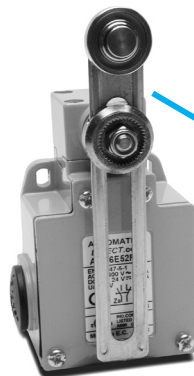

AGE52-LEVER

(Replacement lever shown installed on ABM5E52Z11 limit switch)

AGE44-LEVER

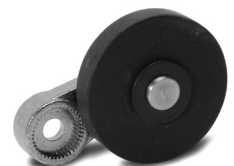

AGE54-LEVER

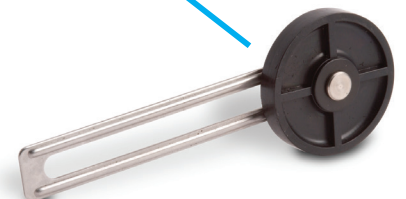

General Specifications



Approvals		
All: CENELEC EN 50041, CEI EN 60947-5-1 Plastic models: UL (508), CSA C22.2 No 14-M91		
Environmental		
Degree of Protection	Plastic models: IP65 according to IEC 529 Aluminum models: IP66 according to IEC 144-CEI70-1	
Temperature Range	Plastic models: stocking: -30° to 80°C (-22° to 176° F) working: -25° to 70°C (-13° to 158°F) Aluminum models: stocking: -30° to 80°C (-22° to 176°F) working: -10° to 70°C (14° to 158°F); minimum temperatures assume that the atmosphere is free of moisture, which could cause moving parts to freeze up	
Rated Insulation Voltage	690V (degree of pollution 3)	
Mechanical Ratings		
Working Positions	All actuators can be rotated in 90° increments (although some types of actuator, such as a long, heavy spring with the adjustable actuator fully extended, may not work properly if installed in a horizontal position).	
Mechanical Life	Straight line working heads: 30 million operations, side rotary heads: 25 million operations, multidirectional heads: 10 million operations	
Enclosure Material	Plastic models: fiberglass-reinforced plastic-V0 class (UL94); aluminum models: die cast aluminum	
Contact Blocks Rating		
Positive Opening*	Yes, all models	
Electrical Ratings	AC15	Make: 60A@120VAC; 30A @ 240VAC; 18A @ 400VAC Break: 10A @ 24VAC; 6.5A @130VAC; 3.1A @ 230VAC; 1.8A @ 400VAC
	DC13	2.8A @ 24VDC; 0.5A @ 110VDC
Maximum Switching Frequency	Contact blocks: all two cycles per second	
Repeat Accuracy	0.01mm on the operating points at 1 million operations	
Short-Circuit Protection	Cartridge fuses gl 10A-500V 10.3x38 1 100KA	
Contact Resistance	25 milli Ω	
Recommended Minimum Operating Speed	With snap-action contacts: 20mm per minute** With slow-action contacts: 500mm per minute***	
Rated Insulation Voltage	660V	
Terminals Marking	According to CENELEC EN 50013	
Wiring Connections	2 x 2.5mm ² (AWG14) to 2 x 0.5mm ² (AWG18)	
Wiring Terminal Type	Captive screw with self-lifting pressure plate	
Wiring Terminal Markings	According to CENELEC EN50013	
User Protection	Double insulation (plastic models only)	
Contact Blocks Performance		
Operation Frequency	3600 ops/h	
Electrical Durability (according to IEC 947-5-1)	Utilization categories AC-15 and DC-13; load factor of 0.5. See table and curves below.	
Tools Needed		
Phillips screwdriver, #1 #2 / Hex wrench, 10mm		

* Positive opening in a snap-action contact block is performed by a rigid mechanism that forces the N.C. contact to open in case the snap action mechanism fails. This would provide protection if, for example, the contacts became "welded" together by excessive current rush. Generally, positive opening is not considered to work properly on switches with actuators that are not a solid design (such as a spring or rubber roller), despite the fact that the contact block itself has positive opening. In order to be considered as having positive opening, a switch must not have flexible components between actuator actioning points and the electrical contact.

** This is the speed at which snap-action contact blocks are tested. There is no minimum operating speed for snap-action contacts because the speed has no influence on the switch action. When using spring actuators, the changeover time may vary from 1 to 3 ms from max. to min. operating speed.

*** Slow-action contacts must not be operated at very low speeds because of the tendency to maintain the arc if contacts are not rapidly separated.

Electrical Durability (according to IEC 947-5-1)

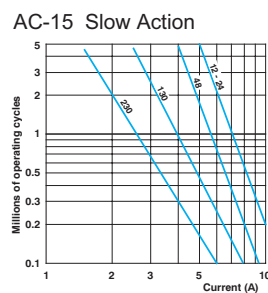
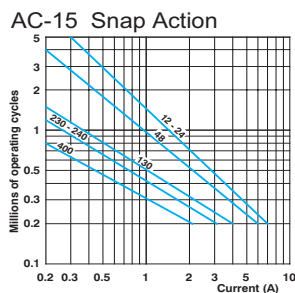

DC-13	Snap Action	Slow Action
	Power breaking for a durability of 5 million cycles	
24 Volts	9.5W	12W
48 Volts	6.8W	9W
110 Volts	3.6W	6W

IEC Limit Switches Bar Charts

Limit switch types

Snap-action contact: A contact element in which the contact motion is independent of the speed of the actuator. This feature ensures reliable electrical performance even in applications involving very slow moving actuators.

Slow-make/slow-break contacts: A contact element in which the contact motion is dependent on the actuator speed.

Terminal identification (IEC)

Each terminal is marked with two digits. The first digit indicates the pole (circuit). The second digit indicates the type of contact.

1-2 is N.C., 3-4 is N.O.
so 11-12, 21-22 are N.C., while 13-14, 23-24 are N.O.

Terminal Markings	
European	
Terminal No.	Type
11-12	N.C. contact of pole no. 1 ¹
13-14	N.O. contact of pole no. 2 ¹
21-22	N.C. contact of pole no. 2 ²
23-24	N.O. contact of pole no. 1 ²

¹ With non-isolated contacts ² With isolated contacts

Note: Green/yellow wire is physical earth ground.

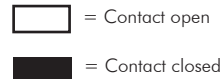

Make-before-break (overlapping) SPDT: the N.O. contact closes before the N.C. contact opens. (See ex: Y11)



Break-before-make (offset) SPDT: the N.C. contact opens before the N.O. contact closes. (See ex: X11)



Simultaneous make and break SPDT: the N.C. contact opens at the same time as the N.O. contact closes. (See ex: Z11)

Contacts Configuration

Z11 Snap Action Contacts

1 N.O. and 1 N.C.

A = Max. travel of the operator in mm or degrees
B = Tripping travel of both contacts on actuation
C = Tripping travel of both contacts on release
D = Differential travel (between actuation and release)
P = Point from which positive opening is assured during actuation

Bar Chart Examples (cam angle is 30 degrees)

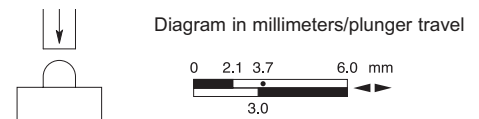
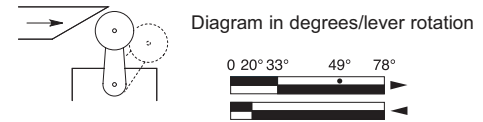
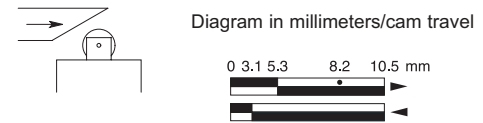

Part Series	Displacement Values (mm [in] or degrees)			
	A	B	C	P
ABMxE11Z11	6.0 [0.24]	3.0 [0.12]	1.8 [0.07]	4.6 [0.18]
ABMxE13Z11	10.5 [0.41]	5.3 [0.21]	3.1 [0.12]	8.2 [0.32]
ABMxE32Z11	15.5 [0.61]	6.3 [0.25]	3.1 [0.12]	10.8 [0.43]
ABMxE42Z11	78°	33°	20°	49°
ABMxE52Z11	78°	33°	20°	49°
ABMxE71Z11	78°	33°	20°	49°
ABMxE92Z11	—	21°	9°	—
ABMxE93Z11	—	21°	21°	—
ABPxH14Z11	5.9 [0.23]	2.2 [0.09]	1.0 [0.04]	3.8 [0.15]
ABPxH19Z11	10.5 [0.41]	4.6 [0.18]	2.4 [0.09]	7.5 [0.30]
ABPxH35Z11	17 [0.67]	6.8 [0.27]	3.8 [0.15]	11.3 [0.44]
ABPxH41Z11	90°	31°	19°	47°
ABPxH51Z11	90°	31°	19°	47°
ABPxH71Z11	90°	31°	19°	47°
ABPxH92Z11	—	27°	15°	—
ABPxH93Z11	—	27°	15°	—
AAP2T14Z11	9.6 [0.38]	4.7 [0.19]	2.5 [0.10]	7.6 [0.30]
AAP2T13Z11	5.5 [0.22]	2.5 [0.10]	1.3 [0.05]	4.1 [0.16]
AAP2T35Z11	21 [0.83]	9 [0.35]	4.9 [0.19]	14.5 [0.57]
AAP2T41Z11	74°	31°	17°	47°
AAP2T51Z11	74°	31°	17°	47°
AAP2T71Z11	74°	31°	17°	47°

Changeable working heads (E42, E52, E71) models; view of cam insert when looking at bottom of head once removed from switch body.

To change position, push in and twist until it locks into place

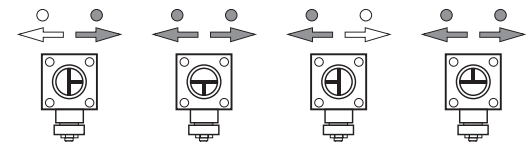

Positioning - 90° each way

Adjustable lever from 0-360°, 6° each increment

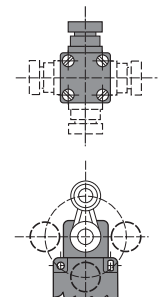

IEC Limit Switches Dimensions

Switch body dimensions

Dimensions are in millimeters. 25.4 mm = 1 inch
 For example, 30 mm to inches = 30/25.4 = 1.181 inches.

Actuators - ABM, ABP models

Figure 5: Steel plunger (ABM, ABP models)

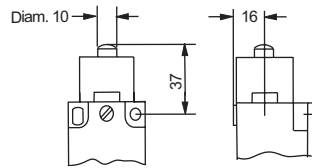

Figure 6: Plunger with roller (ABM, ABP models)

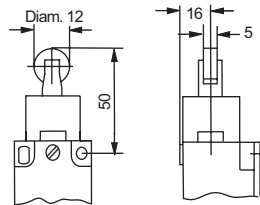

Figure 7: 1-way lever with roller (ABM, ABP models)

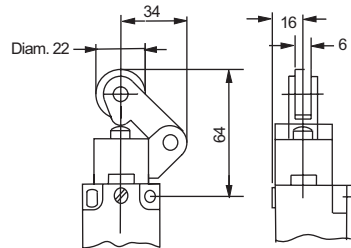

Figure 8: Side rotary with roller (ABM, ABP models)

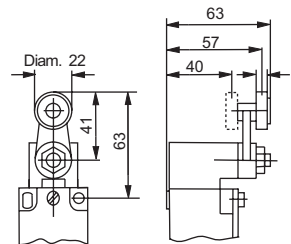

Figure 9: Side rotary with adjustable lever roller (ABM, ABP models)

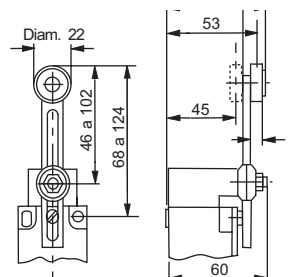

Figure 1: ABM models — single-cable entry style

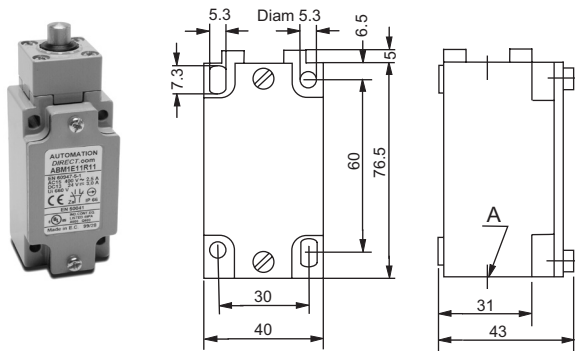

Figure 2: ABM models — 3-cable entry style

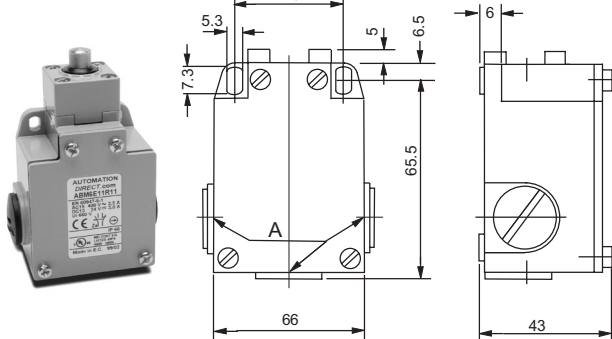

Figure 3: ABP models

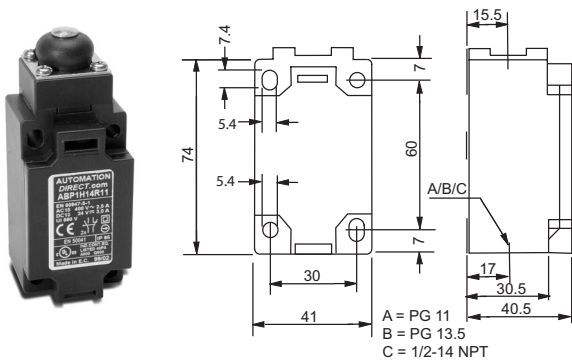
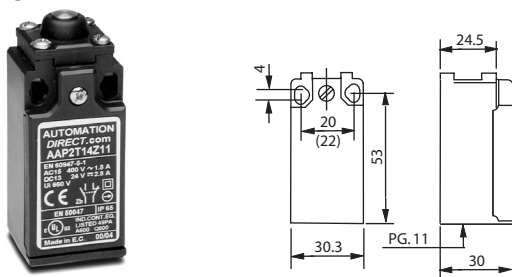

Figure 4: AAP (Mini DIN) models



IEC Limit Switches Dimensions

Figure 10: Side rotary with rod (ABM, ABP models)

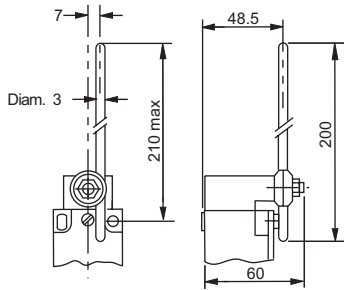

Figure 11: Wobble-type with spring with tip (ABM, ABP models)

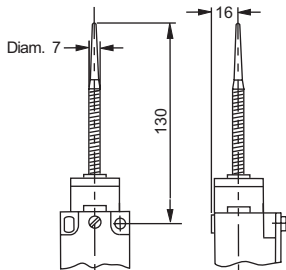

Figure 12: Wobble-type steel spring (ABM, ABP models)

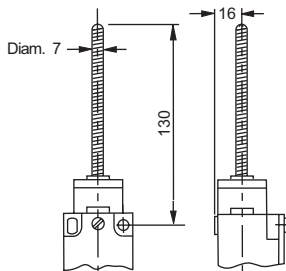

Figure 13: Optional lever arm (ABM models) AGE44-LEVER

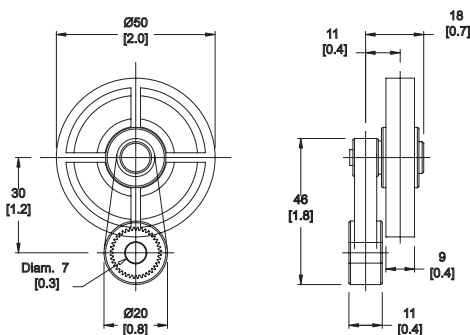
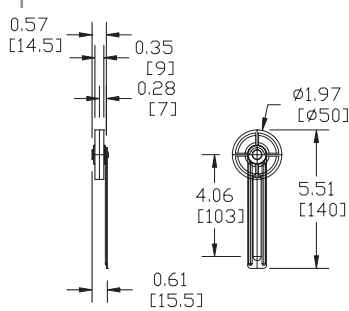

Figure 14: Optional lever arm (ABM models) AGE54-LEVER



Actuators — mini-DIN (AAP) models

Figure 15: Steel plunger (AAP models)

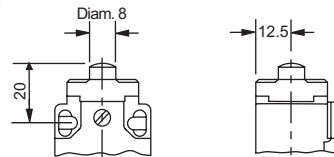

Figure 16: Steel plunger with roller (AAP models)

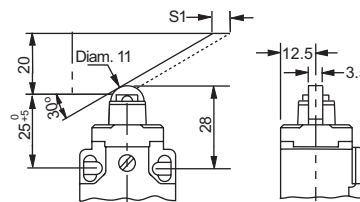

Figure 17: One-way lever with roller (AAP models)

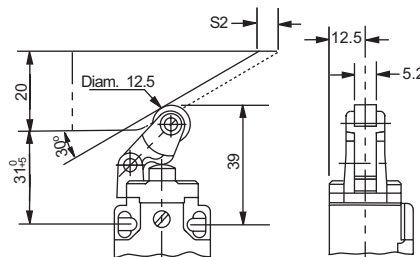

Figure 18: Side rotary lever with roller (AAP models)

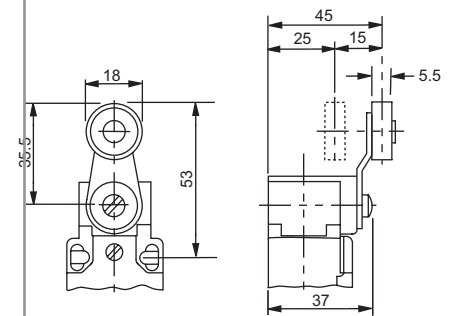

Figure 19: Side rotary lever with adj. lever roller (AAP models)

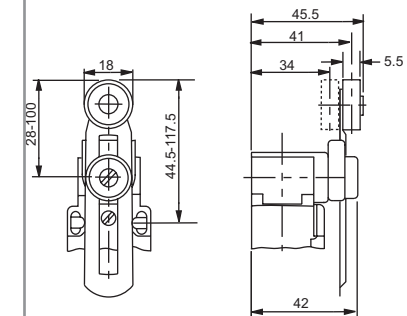
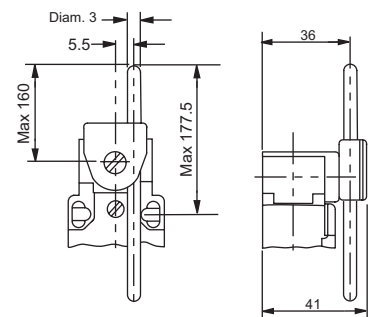

Figure 20: Side rotary lever with rod actuator (AAP models)



Dimensions are in millimeters (25.4 mm = 1 inch). For example, 30mm to inches = 30/25.4 = 1.181 inches.