

WC10 NEMA 12 and 13 Operator Consoles



Applications

Designed to hold electrical and electronic controls and instruments. Heavy duty construction provides protection from dirt, dust, oil and water. Pushbuttons, pilot lights, meters, switches, etc. can be mounted on sloping control surfaces. Interior components can be mounted on subpanel and terminal straps.

Construction

Base

- Fabricated from 14 gauge steel
- Seams are continuously welded and ground smooth
- 3-point keylocking handle is provided on front, main door
- Flush main door
- Control panels are hinged along bottom edge
- Control panels have captivated screws threaded into sealed wells
- Door stops provided to hold control panel open
- Standard closed cell neoprene gasket
- Removable subpanel is included with enclosure
- Grounding provisions provided
- [Uses WAL2 series handles and WAL2KEY replacement key](#)

Top

- Fabricated from 14 gauge steel
- Seams are continuously welded and ground smooth
- Instrument and access panels have captivated screws that thread into sealed wells
- Closed cell neoprene gasket

Writing desk

- Fabricated from 14 gauge steel
- Seams are continuously welded and ground smooth
- Desks are removable and attach easily to console front

Finish

- ANSI 61 gray polyester powder inside and out over phosphatized surfaces
- Included painted steel subpanel is white polyester powder over phosphatized surfaces

Listings

- UL 508, Types 12 and 13 [UL File E64791]
- NEMA/EEMAC Types 12 & 13



Enclosure Shipping Schedule					
Same day	1 - 5 days	1 - 7 days	1 - 10 days	1 - 15 days	1 - 20 days

Color indicates shipping lead time in business days.

WC10 NEMA 12 and 13 Operator Consoles			
Part Number	Price	Enclosure Size HxWxD	Description
WC10B	\$1,891.00	40.13 x 24.13 x 20.12 [1019 x 613 x 511]	Console base
WC10T	\$469.00	16.15 x 24.15 x 5.13 [410 x 614 x 130]	Console top for WC10B
WC10W	\$177.00	3.00 x 24.13 x 10.13 [76 x 613 x 26]	Writing desk for WC10B
WC10C	\$191.00	N/A	Caster kit: Set of 4 casters, 2 mounting plates, and hardware

Notes: Dimensions in inches [millimeters].
 Letters in table correspond to letters on dimensional drawings.
 *Subpanel is included with console.
 Tops, writing desks and caster kits must be ordered separately.

WC12 NEMA 12 and 13 Operator Consoles

Dimensions

In [mm]

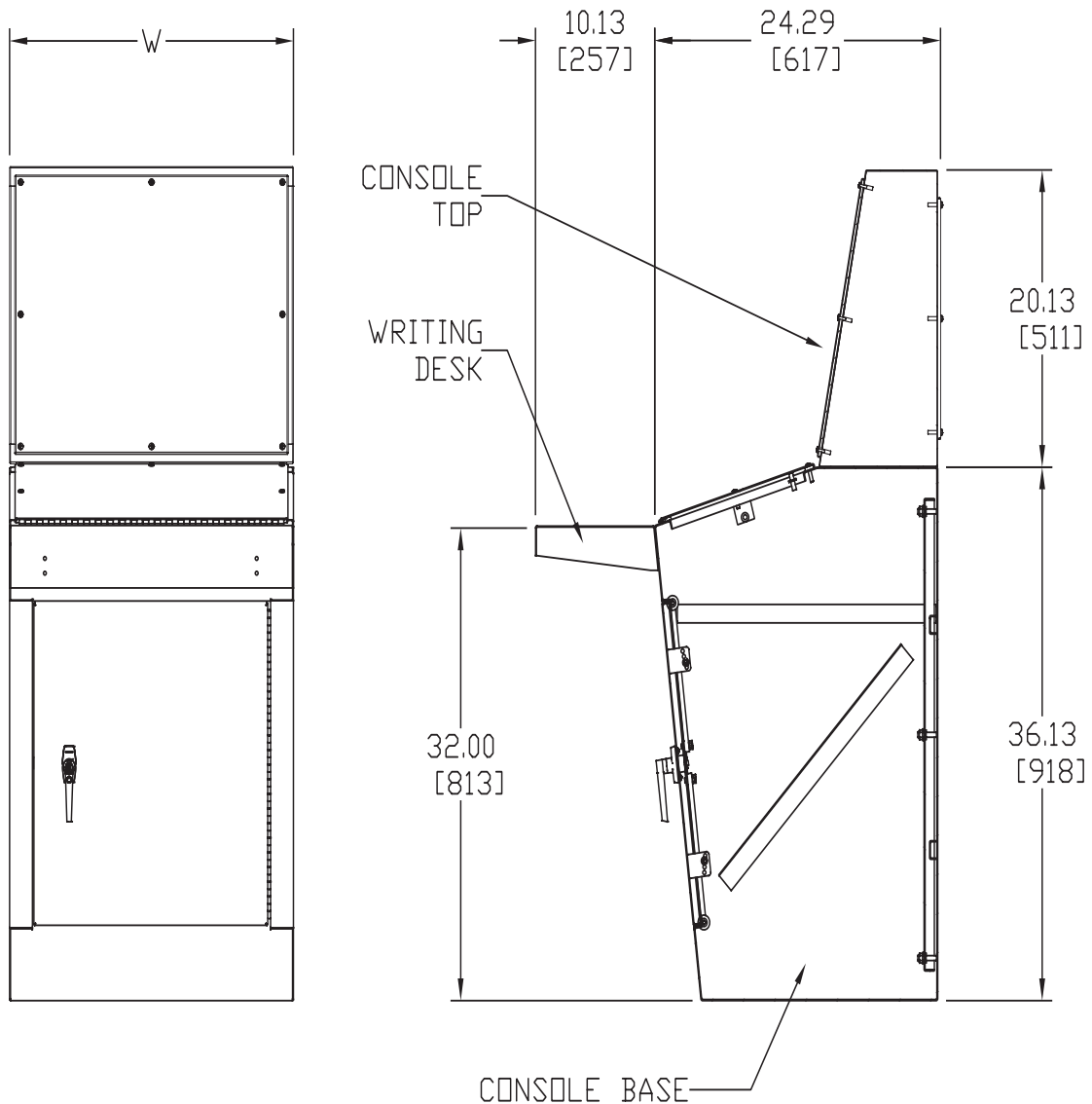

NOTES:

1. ACCESS DOORS OPEN 180 DEGREES.
2. 3-POINT KEY LOCKING HANDLES ARE PROVIDED ON MAIN DOORS
3. WRITING DESK IS PROVIDED WITH MOUNTING HARDWARE.
4. 48" WIDE CONSOLE HAS TWO DOORS.

See our website: www.AutomationDirect.com for complete engineering drawings.

Enclosure Accessories - Mounting Feet, Panel Mounting and Latches

Mounting Feet for Freedom, Commander and Centurion Series Enclosures



AttaBox
A ROBROY ENCLOSURES™ BRAND

Mounting Feet for Freedom, Commander and Centurion Series Enclosures			
Mounting Foot Kit	Price	Description	Wt. [oz]
FRMGFTKIT	\$12.00	AttaBox mounting feet kit, fiberglass-reinforced polyester, for use on Freedom series enclosures. Includes (4) mounting feet and mounting hardware.	1
COMTGFTKIT	\$24.50	AttaBox mounting feet kit, fiberglass-reinforced polyester, for use on Commander series fiberglass, in-line, pushbutton enclosures. Does not fit C0763, C0963, COxPBW series, and COPCxxx series, COPCxB series, and COPCxB22 series enclosures. Includes (2) mounting feet, mounting hardware and silicone adhesive/sealant.	1
CEMTGFTKIT	\$25.00	AttaBox mounting feet kit, fiberglass-reinforced polyester, for use on Centurion series enclosures. Includes (4) mounting feet and mounting hardware.	1



FRMGFTKIT



COMTGFTKIT



CEMTGFTKIT

Enclosure Shipping Schedule			
Same day	1 - 5 days	1 - 15 days	1 - 20 days

Color indicates shipping lead time in business days.

Swing-panel Mounting Kit for MachoBox Series Enclosures

Swing-panel Mounting Kit for MachoBox Series Enclosures			
Mounting Foot Kit	Price	Description	Wt. [oz]
M3024SPMK	\$36.50	AttaBox swing-panel mounting kit, fiberglass-reinforced polyester, for use on 30x24in [762x610mm] MachoBox enclosures and subpanels. Includes (8) mounts and (16) screws.	7



M3024SPMK

Latches For Centurion, Freedom, and Triton Series Enclosures



SSLKIT



FRHLLKIT



TLL150KIT



TLL150WKIT

Latches for Centurion, Freedom, and Triton Series Enclosures		
Latch	Price	Description
SSLKIT	\$20.50	Centurion series luggage style Stainless Steel lockable latch.
FRHLLKIT	\$22.50	Freedom series lockable link latch.
TLL150KIT	\$34.50	Triton Series twist-lock latch. For Type 12, 3R and 4X.
TLL150WKIT	\$34.50	Triton Series twist-lock latch. For 4X top and bottom latches.