

# proense® FSA Series Flow Transmitters

Part No. FSA75-42-6H

Part No. FSA1-42-27H



Part No. FSA75-42-10H

The ProSense FSA Series flow transmitters are ideal for applications with rapid temperature changes or where fast response time is required, such as:

- Machine tool coolant flow
- HVAC cooling water flow
- Injection molding cooling water flow



## Overview

The ProSense FSA Series flow transmitters monitor liquid media and provide an analog output proportional to flow rate for various flow applications.

The ProSense FSA Series sensing principle is based on differential pressure which ensures extremely fast response time and allows for a precise flow measurement. The ProSense flow transmitters are available in three flow ranges up to 27GPM.

## Features

- Measure up to 27GPM (gallons per minute) in 3 models
- Immune to rapid temperature changes of media
- Fast response time of <10ms
- 3/4" or 1" FNPT process connections
- Integrated check valve design allows the sensor to be mounted horizontally or vertically
- 4-pin M12 quick disconnect
- IP65 / IP67
- 2-year warranty



ProSense FSA Series Flow Transmitters				
Part No.	Description	Quantity	Weight (lbs)	Price
FSA75-42-6H	ProSense liquid flow transmitter, 0 to 6 GPM measuring range, 3/4 inch female NPT process connection, 4-20 mA analog output, 18 to 32 VDC operating voltage, 4-pin M12 quick-disconnect electrical connection. Purchase cable separately.	1	1.0	\$148.00
FSA75-42-10H	ProSense liquid flow transmitter, 0 to 10 GPM measuring range, 3/4 inch female NPT process connection, 4-20 mA analog output, 18 to 32 VDC operating voltage, 4-pin M12 quick-disconnect electrical connection. Purchase cable separately.	1	1.0	\$148.00
FSA1-42-27H	ProSense liquid flow transmitter, 0 to 27 GPM measuring range, 1 inch female NPT process connection, 4-20 mA analog output, 18 to 32 VDC operating voltage, 4-pin M12 quick-disconnect electrical connection. Purchase cable separately.	1	1.5	\$174.00

ProSense FSA Series Flow Transmitters Technical Specifications			
Model	FSA75-42-6H	FSA75-42-10H	FSA1-42-27H
Operating Voltage	18 to 32 VDC (SELV/PELV)**		
Electrical Connection	M12 (note: tightening torque <0.6 Nm based on cable)		
Connection Pin Material	Gold-plated		
Output Function	Analog		
Analog Output	4-20 mA (sourcing)		
Maximum Load	500Ω		
Current Consumption	<35mA		
Short-Circuit Protection	YES		
Reverse Polarity Protection	YES		
Overload Protection	YES		
Cycles	10 million minimum		
Response Time	<10ms		
Accuracy*	± 5% of full range		
Repeatability*	± 1% of full range		
Process Connection	3/4" FNPT		1" FNPT
Medium	Liquids (water, glycol solutions, oils), use of 200 micron filter recommended		
Maximum Flow Rate	26.4 GPM		52.8 GPM
Maximum Viscosity	<68 centistokes		
Flow Measuring Range	0 - 6 GPM	0 - 10 GPM	0 - 27 GPM
Pressure Rating	362 psig max operating / 724 psig proof pressure		

\* When used with water @ 20°C [68°F]

\*\* Voltage Supply According to EN50178 SELV (Safety Extra-Low Voltage) / PELV (Protected Extra-Low Voltage)

# proense® FSA Series Flow Transmitters

ProSense FSA Series Flow Transmitters Environmental Specifications			
Model	FSA75-42-6H	FSA75-42-10H	FSA1-42-27H
Housing Material	Brass chemically nickel-plated; PP (Polypropylene); stainless steel (316L / 1.4404); aluminum anodized; PA (Polyamide)		
Materials (wetted parts)	Stainless steel (316 / 1.4401); brass chemically nickel-plated*; PP (Polypropylene); PPS (Polyphenylene sulfide); O-ring:FKM (Viton)		
Operating Temperature	32 to 140°F (0 to 60°C)		
Medium Temperature	14 to 212°F (-10 to 100°C)		
Storage Temperature	5 to 176°F (-15 to 80°C)		
Protection	IP65 / IP67		
Protection Class	III		
Agency Approvals	cULus (#E320431), CE, RoHs		

\* The brass contains between 1-2% lead by weight. Not recommended for use in potable water applications.

**NOTE: CHECK THE CHEMICAL COMPATIBILITY OF THE SENSOR'S WETTED PARTS WITH THE MEDIUM TO BE MEASURED.**

## Wiring Diagrams

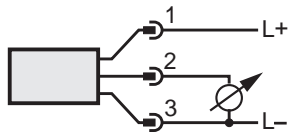

**Cable Assembly Wiring Colors:**  
**Pin 1 - Brown**  
**Pin 2 - White**  
**Pin 3 - Blue**  
**Pin 4 - Black**

Note: Wiring colors are based on AutomationDirect CD12L and CD12M 4-pole cable assemblies.

## Installation\*:

For proper operation, please observe the flow direction arrows on the body of the sensor. The mounting orientation does not effect the operation of the unit.

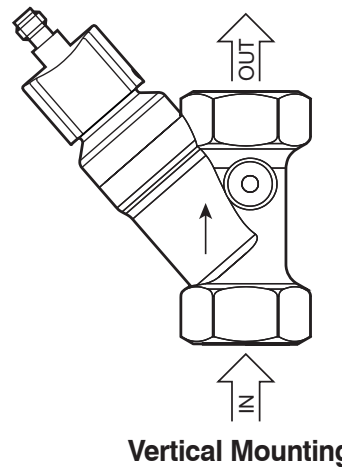
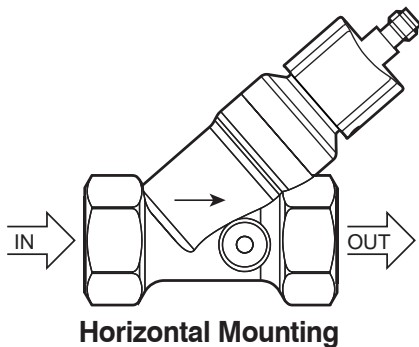

\* Integral check valve design allows the sensor to be mounted in any position.



1. Ferromagnetic materials in the surrounding environment should be at least 50mm from the housing of the unit.
2. Ferromagnetic piping may be used on the inlet and outlet connections.
3. Do not operate the unit in the vicinity of magnetic constant and alternating fields (e.g. welding systems).
4. If the sensors are installed side by side, observe a minimum distance of 50mm between the sensor axes.
5. Avoid downward flow in unpressurized pipes.

# proense® FSA Series Flow Transmitters

## Pressure Loss/Flow Rate\*

**FSA75-42-6H**  
**FSA75-42-10H**

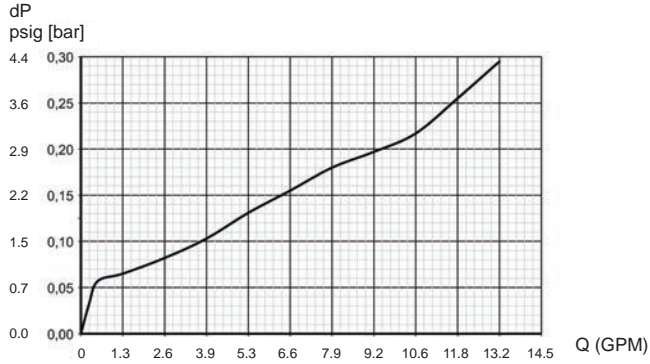

**FSA1-42-27H**

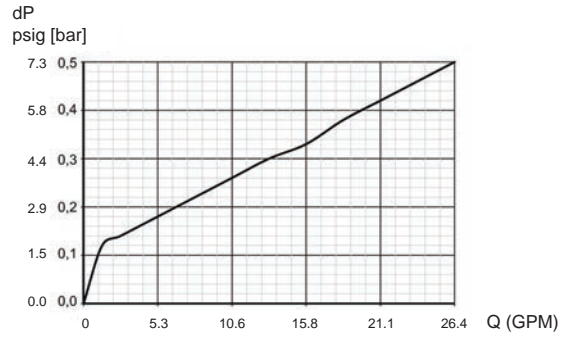

\* when used with water @ 20°C [68°F]

## Dimensions

mm [inches]

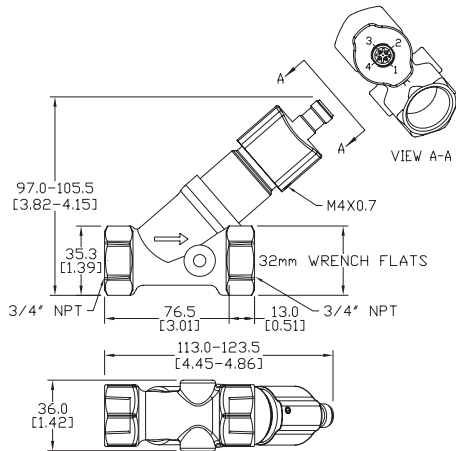

**Part No. FSA75-42-6H**  
**FSA75-42-10H**

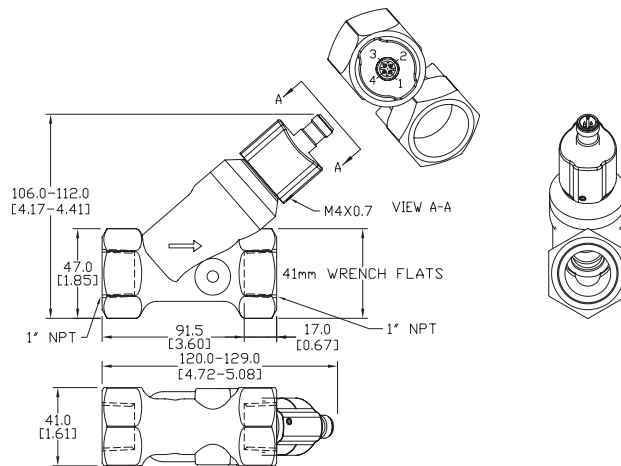

**Part No. FSA1-42-27H**

See our website [www.AutomationDirect.com](http://www.AutomationDirect.com) for complete Engineering drawings.

# proense® FSA Series Flow Transmitters

## Operation

The flow sensor utilizes a spring-supported piston that is lifted by the flowing medium. By monitoring the piston position the flow rate is determined on the principle of differential pressure and is converted into an analog output signal (4 to 20 mA). The spring resets the piston to its initial position with decreasing flow. This allows the sensor to be mounted in any position (horizontally or vertically) and function as a check valve.



Cutaway View

## Function

The analog signal for water (20°C [68°F]) is linear from 4.3 mA to 20mA (4mA = no flow). For an output signal >20mA the flow rate is above the final value of the measuring range.

Part Number	Flow Measuring Range (Gallons/Minute)
FSA75-42-6H	0 to 6
FSA75-42-10H	0 to 10
FSA1-42-27H	0 to 27



Click or scan the above QR code to be taken to the installation insert for the FSA Series Flow Transmitters

## Analog Output Charts

