

# ProSense® VFL Series Vibration Fork Liquid Level Switches



Part No. VFL75-100L-3H



Part No. VFL50-100S-3D

## ProSense Vibration Fork Liquid Level Switches

The ProSense VFL Series of Vibration Fork Level Switches is designed using tuning fork technology for reliable liquid point level detection for monitoring, alarming, and control applications. The device's electronics cause its tuning forks to vibrate at their natural frequency. When the forks come in contact with the medium, the fork vibration frequency will change and trigger the switch output to change state. Suitable for use in tanks, vessels, and pipes, the VFL series is an ideal alternative for applications where other liquid point level technologies such as float switches or conductive, optical and capacitance sensors are not suitable due to conductivity, turbulence, buildup, air bubbles, foam, pressure, temperature, and viscosity changes. The ProSense VFL Series is offered in two process connection sizes with short and extended insertion lengths, standard and high temperature constructions, and a 3-wire DC switch output for connection to controller inputs or a 2-wire AC/DC switch suitable for control of valves and pumps, making the VFL Series perfect for high and low point level alarms, overflow protection, and pump protection in a wide variety of liquid level applications.

### Features

- 1/2" or 3/4" male NPT process connection
- Short or extended insertion lengths
- Standard or high temperature constructions
- 3-wire DC output for PLC inputs or 2-wire AC/DC output for control of valves and pumps
- M12 quick disconnect or DIN style electrical connectors
- Robust stainless steel construction
- LED indication provides visual function check
- External function test with test magnet

### Applications

- Ideal for applications not suitable for other liquid point level technologies due to conductivity, turbulence, buildup, air bubbles, foam, pressure, temperature, and viscosity changes
- Use in tanks, vessels, and pipes for:
  - Overflow protection
  - High and low point level alarms
  - Pump control or limit detection
  - Valve control
  - Run dry or pump protection
  - High-temperature applications



VFL Series Vibration Fork Liquid Level Switch Selection									
Model	Insertion Length	Process Connection	Output Type	Operating Voltage	Electrical Connection	Process Temperature	Price	Weight (lbs)	
VFL50-100S-3H	1.89 in (48mm) (Short Length)	1/2 in Male NPT	Switch PNP, 3-wire, N.O./N.C. complementary	10-30 VDC	4-pin M12 quick-disconnect	-40°F to 212°F (-40°C to 100°C)	\$137.00	0.64	
VFL75-100S-3H		3/4 in Male NPT					\$137.00	0.71	
VFL50-100S-3D		1/2 in Male NPT	Switch PNP, 3-wire, N.O. or N.C.		EN 175301-803-A connector		\$137.00	0.75	
VFL75-100S-3D		3/4 in Male NPT					\$137.00	0.82	
VFL50-150S-3H		1/2 in Male NPT	Switch PNP, 3-wire, N.O./N.C. complementary		4-pin M12 quick-disconnect		-40°F to 302°F (-40°C to 150°C)	\$155.00	0.68
VFL75-150S-3H		3/4 in Male NPT						\$155.00	0.75
VFL50-150S-3D		1/2 in Male NPT	Switch PNP, 3-wire, N.O. or N.C.		EN 175301-803-A connector			\$155.00	0.77
VFL75-150S-3D		3/4 in Male NPT						\$155.00	0.84
VFL50-100L-3H	3.44 in (87.4 mm) (Extended Length)	1/2 in Male NPT	Switch PNP, 3-wire, N.O./N.C. complementary	10-30 VDC	4-pin M12 quick-disconnect	-40°F to 212°F (-40°C to 100°C)		\$151.00	0.69
VFL75-100L-3H		3/4 in Male NPT						\$151.00	0.76
VFL50-100L-3D		1/2 in Male NPT	Switch PNP, 3-wire, N.O. or N.C.		EN 175301-803-A connector			\$151.00	0.80
VFL75-100L-3D		3/4 in Male NPT						\$151.00	0.87
VFL75-100S-2D	1.89 in (48mm) (Short Length)	3/4 in Male NPT	AC/DC, 2-wire, N.O. or N.C.	20-253 VAC/DC	4-pin M12 quick-disconnect	-40°F to 302°F (-40°C to 150°C)	\$137.00	0.85	
VFL75-150S-2D		3/4 in Male NPT					\$155.00	0.85	

# pro<sup>sense</sup>® VFL Series Vibration Fork Liquid Level Switches

VFL Series Vibration Fork Liquid Level Switch Specifications	
<b>Output</b>	
<b>Switch Output</b>	Switching behavior: On/Off 3-wire DC-PNP: Positive voltage signal at the switch output of the electronics (PNP), switching capacity 200mA* 2-wire AC/DC: Load switching in the power supply line (see Wiring section for Load Requirements), switching capacity 250mA*
<b>Operating Modes</b>	The device has two operating modes: maximum safety (MAX) and minimum safety (MIN). By choosing the corresponding operating mode, the user ensures that the device also switches in a safety-oriented manner even in an alarm condition, e.g. if the power supply line is disconnected. <b>Maximum safety (MAX)</b> The device keeps the electronic switch closed as long as the liquid level is below the fork. Sample application: overflow prevention <b>Minimum safety (MIN)</b> The device keeps the electronic switch closed as long as the fork is immersed in liquid. Sample application: Dry running protection for pumps The electronic switch opens if the limit is reached, if a fault occurs or the power fails (quiescent current principle).
<b>Electrical</b>	
<b>Supply Voltage</b>	DC-PNP: 10 to 30 V DC, 3-wire AC/DC: 20 to 253 V AC/DC, 2-wire
<b>Power Consumption</b>	DC-PNP: < 975mW AC/DC: < 850mW
<b>Current Consumption</b>	DC-PNP: < 15mA AC/DC: < 3.8 mA
<b>Residual Ripple</b>	DC-PNP: 5Vss 0 to 400Hz AC/DC: N/A
<b>Electrical Connection</b>	Electronic version 3-wire DC-PNP with M12 plug or valve plug connection Electronic version 2-wire AC/DC with valve plug connection A fine-wire fuse is necessary for operation: 500mA slow-blow. <b>Electronic version 3-wire DC-PNP</b> 3-wire DC-PNP is preferably used in conjunction with programmable logic controllers (PLC) Voltage source: non-hazardous contact voltage or Class 2 circuit (North America).
<b>Cable Specification</b>	Valve plug: – Cable cross-section: max. 1.5 mm <sup>2</sup> (16AWG) – Ø 3.5 to 8mm (0.14 to 0.26 in) M12 connector: IEC 60947-5-2
<b>Overvoltage Protection</b>	Overvoltage category II
<b>Reverse Polarity Protection</b>	<b>2-wire AC/DC:</b> AC mode: the device reverse polarity protection does not apply. DC mode: in the event of reverse polarity the maximum safety mode is always detected. Check the wiring and perform a function check before commissioning. The device is not damaged in the event of reverse polarity. <b>3-wire DC-PNP:</b> Integrated. In the event of reverse polarity, the device is deactivated automatically.
<b>Short-Circuit Protection</b>	<b>2-wire AC/DC:</b> During switching the sensor checks whether a load, e.g. relay or contactor, is present (load check). If an error occurs, the sensor is not damaged. Smart monitoring: normal operation is resumed once the error is fixed. <b>3-wire DC-PNP:</b> Overload protection/short-circuit protection at I > 250 mA; the sensor is not destroyed. Intelligent monitoring: Testing for overload at intervals of approx. 1.5 s; normal operation resumes once the overload/short-circuit has been rectified.
<b>Performance</b>	
<b>Reference Operating Conditions</b>	Ambient temperature: +25°C (+77°F) Process pressure: 1 bar (14.5 psi) Fluid: Water (density: approx. 1 g/cm <sup>3</sup> , viscosity 1 mm <sup>2</sup> /s) Medium temperature: 25°C (77°F) Density setting: > 0.7 g/cm <sup>3</sup> Switching time delay: Standard (0.5 s, 1s)
<b>Switch Point</b>	13mm (0.51 in) ±1mm
<b>Hysteresis</b>	max. 3mm (0.12 in)
<b>Non-Repeatability</b>	±1 mm (0.04 in) in accordance with DIN 61298-2
<b>Influence of Ambient Temperature</b>	Negligible
<b>Influence of Medium Temperature</b>	–25 µm (984 µin) / °C
<b>Influence of Medium pressure</b>	–20 µm (787 µin) / bar
<b>Switching Delay</b>	0.5 s when tuning fork is covered 1.0 s when tuning fork is uncovered
<b>Switch-On Delay</b>	max. 3s
<b>Measuring Frequency</b>	approx. 1,100 Hz in air
<b>Measured Error</b>	In event of device change: ± 2mm (0.08 in) as per DIN 61298-2

\*50°C (122°F) ambient maximum. See Operating Instructions for Derating Curve for ambient temperatures to 70°C (158°F).

# prosense® VFL Series Vibration Fork Liquid Level Switches

VFL Series Vibration Fork Liquid Level Switch Specifications Continued	
<b>Process</b>	
<b>Process Temperature Range</b>	-40 to +100°C (-40 to +212°F) -40 to +150°C (-40 to +302°F)
<b>Process Pressure Range</b>	Max. -1 to +40 bar (-14.5 to +580psi)
<b>Density</b>	> 0.7 g/cm <sup>3</sup>
<b>State of Aggregation</b>	Liquid
<b>Viscosity</b>	1 to 10,000 mPa·s, dynamic viscosity
<b>Solids Contents</b>	ø < 5mm (0.2 in)
<b>Lateral Loading Capacity</b>	Lateral loading capacity of the tuning fork: maximum 200 N
<b>Environment</b>	
<b>Ambient Temperature Range</b>	-40 to +70°C (-40 to +158°F)
<b>Storage Temperature</b>	-40 to +85°C (-40 to +185°F)
<b>Climate Class</b>	DIN EN 60068-2-38/IEC 68-2-38: test Z/AD
<b>Altitude</b>	Up to 2,000 m (6,600 ft) above sea level
<b>Degree of Protection</b>	IP65/67 NEMA Type 4X Enclosure (M12 connector) IP65 NEMA Type 4X Enclosure (valve plug)
<b>Shock Resistance</b>	a = 300 m/s <sup>2</sup> = 30 g, 3 planes x 2 directions x 3 shocks x 18 ms, as per test Ea, prEN 60068-2-27:2007
<b>Vibration Resistance</b>	a(RMS) = 50 m/s <sup>2</sup> , ASD = 1.25 (m/s <sup>2</sup> )/Hz, f = 5 to 2,000 Hz, t = 3 x 2 h, as per test Fh, EN 60068-2-64:2008
<b>Electromagnetic Compatibility</b>	Electromagnetic compatibility in accordance with all relevant requirements of the EN 61326 series and NAMUR recommendation EMC (NE21).
<b>Approvals</b>	
<b>CSA</b>	File# 600062
<b>CE</b>	EMC; LVD; RoHS II

## Application Examples

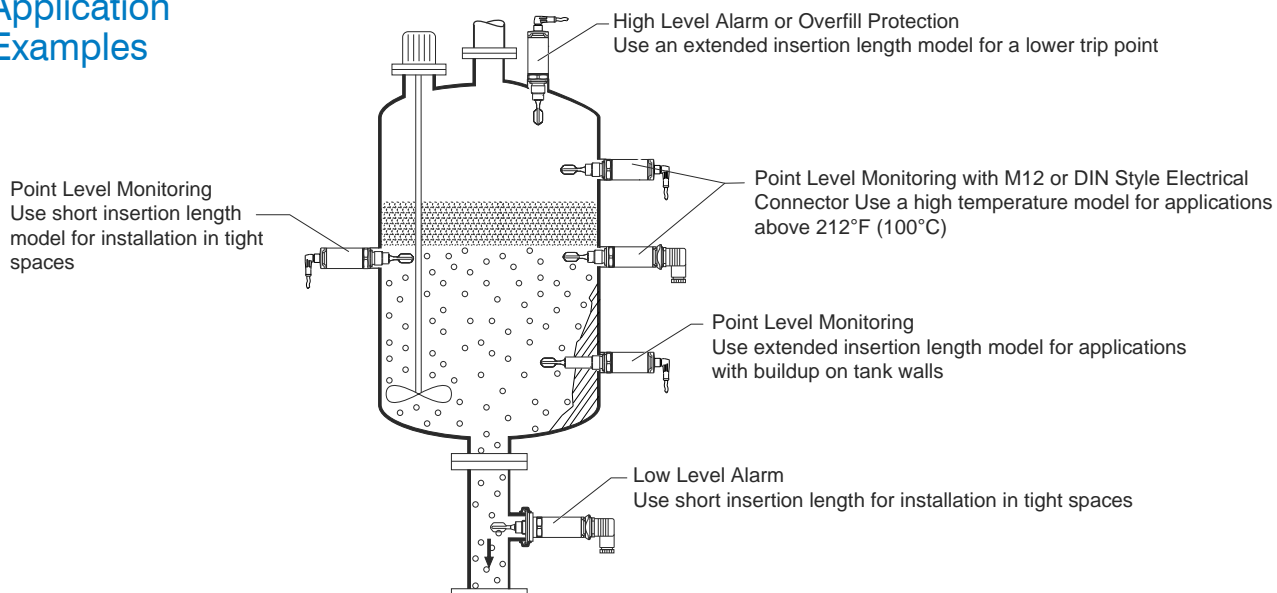

# prosense® VFL Series Vibration Fork Liquid Level Switches

## Wiring

The device has two operating modes: maximum safety (MAX) and minimum safety (MIN). By choosing the corresponding operating mode, the user ensures that the device also switches in a safety-oriented manner even in an alarm condition, e.g. if the power supply line is disconnected.

- **Maximum safety (MAX)**

The device keeps the electronic switch closed as long as the liquid level is below the fork. Sample application: overflow prevention

- **Minimum safety (MIN)**

The device keeps the electronic switch closed as long as the fork is immersed in liquid. Sample application: Dry running protection for pumps

The electronic switch opens if the limit is reached, if a fault occurs or the power fails (quiescent current principle).

## 3-Wire DC-PNP Output - M12 Connector

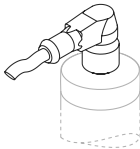
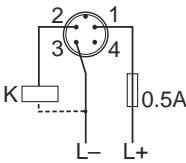
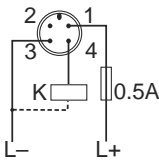
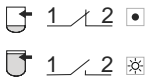
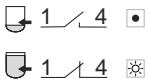
Electrical connection	Operating mode	
M12 connector 	<b>MAX</b> 	<b>MIN</b> 
		
<ul style="list-style-type: none"> <li>◻ Yellow LED not lit</li> <li>⊗ Yellow LED lit</li> <li>K external load</li> </ul>		

IEC 60947-5-2

## Function Monitoring

### Function monitoring with M12 connector

Using a two-channel analysis, function monitoring of the sensor can be implemented in addition to level monitoring, e.g. per relay switch, PLC, I/O module, ....

When both outputs are connected, the MIN and MAX outputs assume opposite states when the device is operating fault-free (XOR). In the event of an alarm condition or a line break, both outputs are deenergized.

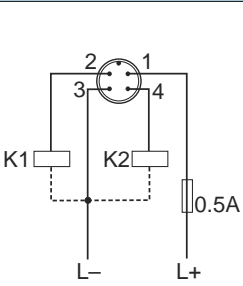
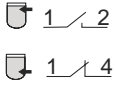
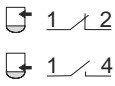
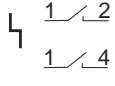
Connection for function monitoring		Yellow LED	Red LED
	Sensor covered 	⊗	•
	Sensor exposed 	•	•
	Fault 	•	⊗
<ul style="list-style-type: none"> <li>⊗ LED lit</li> <li>• LED not lit</li> <li>⚡ Fault or warning</li> <li>K1 / K2 external load</li> </ul>			

IEC 60947-5-2



# prosense® VFL Series Vibration Fork Liquid Level Switches

## Wiring Continued

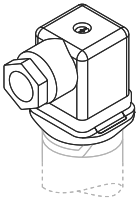
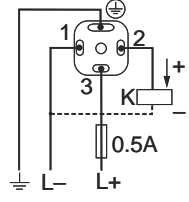
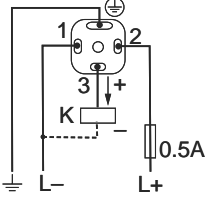
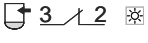
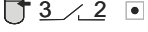
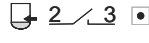
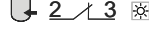
### 3-Wire DC-PNP Output - Valve Plug

Electrical connection	Operating mode	
	<b>MAX</b> 	<b>MIN</b> 
	 	 
<p> <span style="border: 1px solid black; padding: 2px;">•</span> Yellow LED not lit  <span style="border: 1px solid black; padding: 2px;">☼</span> Yellow LED lit  <b>K</b> external load                 </p> <p style="text-align: right;">Valve plug cable Ø 3.5 to 8 mm (0.14 to 0.26 in)</p>		

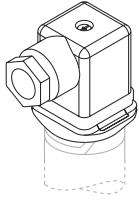
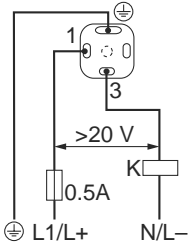
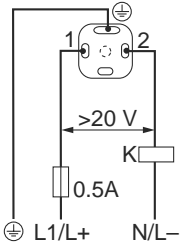
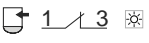
### 2-Wire AC/DC Output

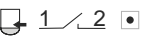
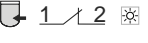
Electrical connection	Operating mode	
	<b>MAX</b> 	<b>MIN</b> 
	 	 
<p> <span style="border: 1px solid black; padding: 2px;">•</span> Yellow LED not lit  <span style="border: 1px solid black; padding: 2px;">☼</span> Yellow LED lit  <b>K</b> external load                 </p> <p style="text-align: right;">Valve plug cable Ø 3.5 to 8 mm (0.14 to 0.26 in)</p>		

### Load Requirements

Mode	Supply voltage	Rated power	
		min	max
AC mode	24 V	> 1.3 VA	< 6 VA
	110 V	> 1.5 VA	< 27.5 VA
	230 V	> 2.5 VA	< 57.5 VA
DC mode	24 V	> 0.7 W	< 6 W
	48 V	> 0.9 W	< 12 W
	60 V	> 1.5 W	< 15 W

Not suitable for connection to PLC inputs!

Refer to Operating Instructions document for additional information.

# prosense® VFL Series Vibration Fork Liquid Level Switches

## Dimensions mm [inches]

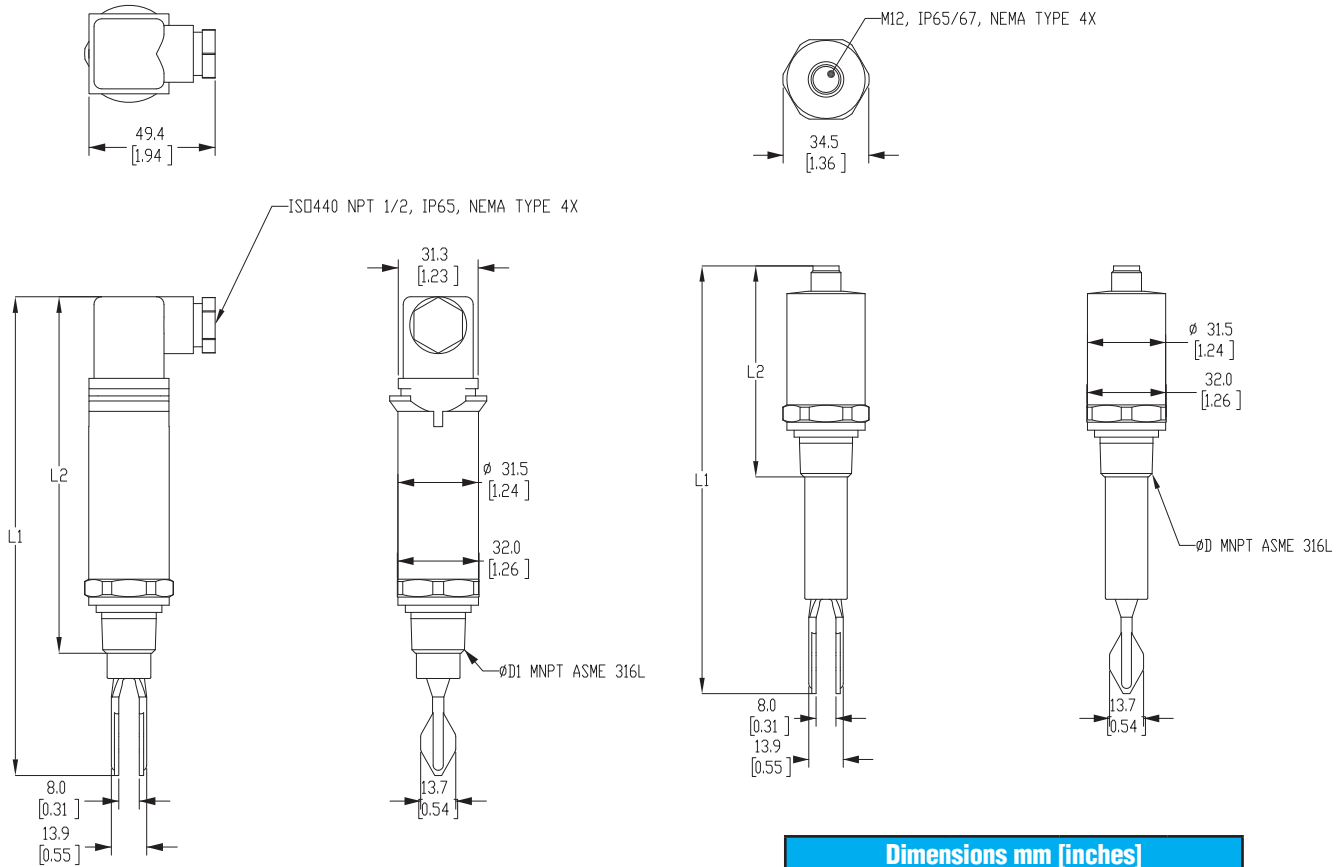

Dimensions mm [inches]			
Part No.	L1	L2	ØD
VFL75-150S-2D	187.5 [7.38]	139.6 [5.50]	3/4
VFL75-100S-2D	162.9 [6.41]	115.0 [4.53]	3/4
VFL50-100L-3D	202.3 [7.96]	115.0 [4.53]	1/2
VFL75-100L-3D	202.3 [7.96]	115.0 [4.53]	3/4
VFL50-150S-3D	187.5 [7.38]	139.6 [5.50]	1/2
VFL75-150S-3D	187.5 [7.38]	139.6 [5.50]	3/4
VFL50-100S-3D	162.9 [6.41]	115.0 [4.53]	1/2
VFL75-100S-3D	162.9 [6.41]	115.0 [4.53]	3/4

Dimensions mm [inches]			
Part No.	L1	L2	ØD
VFL50-100L-3H	172.3 [6.78]	85.0 [3.35]	1/2
VFL75-100L-3H	172.3 [6.78]	85.0 [3.35]	3/4
VFL50-150S-3H	157.5 [6.20]	109.6 [4.31]	1/2
VFL75-150S-3H	157.5 [6.20]	109.6 [4.31]	3/4
VFL50-100S-3H	132.9 [5.23]	85.0 [3.35]	1/2
VFL75-100S-3H	132.9 [5.23]	85.0 [3.35]	3/4

See our website [www.AutomationDirect.com](http://www.AutomationDirect.com) for complete Engineering drawings.