



# EchoPod® & EchoSonic® II Ultrasonic Liquid Level Sensors



The EchoPod and EchoSonic II are innovative ultrasonic liquid level sensor families that replace float, conductance and pressure sensors that fail due to contact with dirty, sticky and scaling media in small, medium and large capacity tanks. Applied in chemical, water and wastewater applications, these general purpose non-contact sensors are available with single and multi-function capabilities including continuous level measurement, switching and control.

For input to a PLC or other controller, measurement outputs include current, voltage and frequency. Models with four relays can be configured for level alarms and/or stand-alone level control such as automatic fill or empty functions using the embedded level controller. PC configuration is simple with WebCal™ software.



EchoPod & EchoSonic II Ultrasonic Liquid Level Sensors General Specifications											
<b>Model</b>	<i>DL34-00</i>	<i>DL24-00</i>	<i>DL14-00</i>	<i>DS14-00</i>	<i>DX10-00</i>	<i>DL10-00</i>	<i>LU27-00</i>	<i>LU23-00</i>	<i>LU28-00</i>	<i>LU29-00</i>	
<b>Price</b>	\$556.00	\$464.00	\$371.00	\$348.00	\$297.00	\$324.00	\$524.00	\$623.00	\$721.00	\$819.00	
<b>Type</b>	EchoPod						EchoSonic II				
<b>Class</b>	General Purpose (non-hazardous)										
<b>Media*</b>	Liquids										
<b>Range</b>	8in to 18 ft (20cm to 5.5 m)	4in to 9.8 ft (10cm to 3m)	2in to 4.1 ft (5cm to 1.25 m)				4in to 9.8 ft (10cm to 3m)	8in to 18 ft (20cm to 5.5 m)	8in to 26.2 ft (20cm to 8m)	8in to 32.8 ft (20cm to 10m)	
<b>Output Types</b>	4-20 mA and (4) SPST relays			(4) SPST relays	0-5V, 0-10V, 976-2000 Hz	4-20 mA					
<b>Install</b>	Vertical, top of tank										
<b>Mounting</b>	2in MNPT		1in MNPT				2in MNPT				
<b>Relays</b>	(4) SPST					No Relay					
<b>Configuration</b>	WebCal Software (free download) and LI99-2001 Fob USB Adapter (purchased separately)										
<b>Ambient Temperature</b>	-31° to 140°F (-35° to 60°C)										
<b>Process Temperature</b>	20° to 140°F (-7° to 60°C)						-4° to 140°F (-20° to 60°C)				
<b>Pressure</b>	30 PSI (2 bar) max.										

\* Any factor that negatively affect sound's ability to travel such as, vapor, condensation, foam, turbulence, vacuum, etc., will have a negative effect on the ultrasonic sensor signal and should be avoided. For condensing environments the Flowline UG/US series of Reflective Ultrasonic Level Sensors are recommended.

## WebCal Software



WebCal



LI99-2001

WebCal PC software is a utility program that allows users to easily configure their EchoSonic II and EchoPod level transmitters, switches, and controllers. Download your free copy of WebCal at [www.AutomationDirect.com](http://www.AutomationDirect.com), and connect your sensor through our Fob USB adapter (LI99-2001). Develop your configuration using pre-programmed function menus as the tank graphic and set point fields automatically change to match your configuration. Then, input your level set point values and click the Write to Unit button. Your configuration will be downloaded into the sensor and verified in less than a second. Last, click the Wiring Diagram button to open a wiring schematic of your configuration in PDF format. Print the document, disconnect the sensor and wire it per the schematic. As new software or firmware becomes available, they can be downloaded and updated through WebCal.

## PodView®



LI40-1001

The PodView digital level indicator is a low cost general purpose level indicator that displays engineering units for level or volume and shares power with an EchoPod ultrasonic sensor, including loop powered devices. The LI40 can be field mounted for local indication as well as be used to make simple setting changes to the sensor. The display can be easily attached to any EchoPod sensor that has been configured with WebCal 6.0 / firmware 50.0 or higher. PodView displays sensor output and can reconfigure sensor setpoints on the fly. PodView shares power with the sensor and does not require any additional outside power supply.



Click on the thumbnail or go to <https://www.automationdirect.com/VID-LE-0003> for a short video introduction to Flowline Ultrasonic Level Switches.



Click on the thumbnail or go to <https://www.automationdirect.com/VID-LE-0002> for a short video introduction to Flowline EchoTouch, EchoSpan, EchoSwitch and PodView product lines.



# EchoPod DS14 Ultrasonic Liquid Level Switch & Controller



## Overview

The EchoPod DS14 ultrasonic liquid level switch provides continuous level detection up to 4.1 ft (1.25m), with 4 programmable relays for level switch or level control functions, and is configured via WebCal software. The embedded level controller can lower cost by replacing external control hardware. This non-contact liquid level sensor is ideally suited for corrosive, sticky or dirty liquids, and is broadly selected for small day tank, skid, intermediate bulk tanks, sump and process tank level applications.

## Features

- Continuous level detection up to 4.1 ft (1.25 m)
- Configuration is fast and easy via WebCal software and USB adapter
- Narrow 2 inch beam width and short 2 inch dead band optimized for small tanks
- Four programmable relays for switch, pump or valve control and fail-safety
  - 1 pump or valve with 3 alarms
  - 2 pumps (lead-lag) with 2 alarms
  - 2 pumps (duplexing) with 2 alarms
  - 4 independent outputs
- PVDF transducer and NEMA Type 6P polycarbonate enclosure for corrosive liquids, UV stable for outdoor use
- Automatic temperature compensation for accurate measurement
- Made in the USA

DS14-00 Technical Specifications	
<b>Price</b>	\$348.00
<b>Range</b>	2in to 4.1 ft (5cm to 1.25 m)
<b>Accuracy</b>	0.125 in (3mm)
<b>Resolution</b>	0.019 in (0.5 mm)
<b>Sensing Dead Band*</b>	2in (5cm)
<b>Beam Width</b>	2in (5cm)
<b>Configuration</b>	WebCal Free Software and LI99-2001 USB Fob Adapter
<b>Memory</b>	Non-volatile
<b>Supply Voltage</b>	12 to 24 VAC/VDC
<b>Consumption</b>	0.5W
<b>Output Type</b>	(4) SPST relays
<b>Contact Voltage Ratings</b>	120 VAC/DC @ 0.5A; 30 VAC/DC @ 1A
<b>Contact Fail-Safe</b>	Power loss: Hold last Echo loss: Open, close or hold last
<b>Hysteresis</b>	Selectable
<b>Process Temperature</b>	20° to 140°F (-7° to 60°C)
<b>Temp. Compensation</b>	Automatic
<b>Ambient Temperature</b>	-31° to 140°F (-35° to 60°C)
<b>Pressure</b>	30 PSI (2 bar) MAX
<b>Enclosure Rating</b>	NEMA Type 6P, IP67, encapsulated, corrosion resistant & submersible, UV stable
<b>Enclosure Material</b>	Polycarbonate
<b>Strain Relief Material</b>	Santoprene
<b>Transducer Material</b>	Polyvinylidene Fluoride
<b>Cable Jacket Material</b>	Polyurethane
<b>Cable Type</b>	9-conductor, shielded
<b>Cable Length</b>	48in (1.2 m)
<b>Process Mount</b>	1in MNPT (See accessories for installation fittings)
<b>Mount Gasket</b>	Viton® (included, replacement part number 204038)
<b>Weight (lbs)</b>	0.5
<b>Classification</b>	General purpose
<b>Compliance</b>	CE, RoHS
<b>Agency Approvals</b>	cFMus

## Agency Approvals

- cFMus



## Dimensions inches [mm]

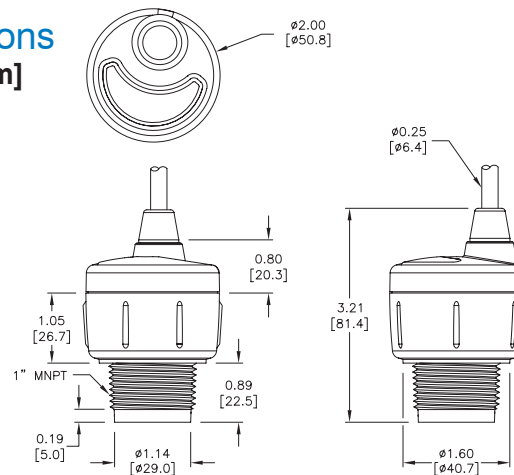

See our website [www.AutomationDirect.com](http://www.AutomationDirect.com) for complete Engineering drawings.

## Configuration

The settings for the the DS14 are configured with free WebCal software (downloadable from AutomationDirect Web site), and an LI99-2001 Fob USB adapter (purchased separately).

## Wiring

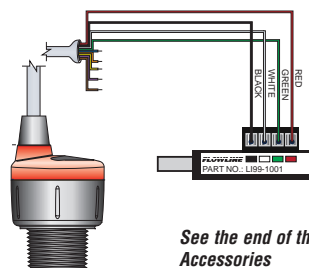
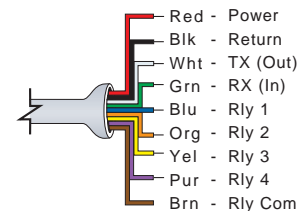

LI99-2001

See the end of the Ultrasonic Level Sensor Section for further details and Accessories

\* Dead band is the minimum distance the sensor must be mounted above the max liquid level.

# FLOWLINE™ PodView® Digital Level Indicator

LEVEL BEST



## Overview

The PodView digital level indicator is a low cost general purpose indicator that displays engineering units for level or volume when combined with an EchoPod DL, DS and DX series ultrasonic sensor that has been configured with WebCal 6.0 / firmware 50.0 or higher. The LI40 can be field mounted for local indication as well as be used to make simple setting changes to the sensor. PodView displays sensor output and can reconfigure sensor set points on the fly without needing to connect to a PC. PodView shares power with the EchoPod DL, DS and DX series sensor and does not require any additional separate power supply.

LI40-1001 Technical Specifications	
<b>Price</b>	\$206.00
<b>Display Type</b>	LCD, 6-digit with 4 relay indicators
<b>Display (Engineering Units)</b>	Level or Volume
<b>Character Height</b>	0.374 in (9.5 mm)
<b>Linearization</b>	per sensor configuration
<b>User Interface</b>	Three button
<b>Input</b>	EchoPod DL, DS and DX sensor family
<b>Memory</b>	Non-volatile
<b>Supply Voltage</b>	12-28 VDC power shared with sensor (EchoPod not to exceed 28 VDC)
<b>Operating Temperature</b>	-4°F to 140°F (-20°C to 60°C)
<b>Cable Type</b>	4-conductor, 22 AWG (0.33 mm <sup>2</sup> )
<b>Cable Length</b>	4ft (1.2 m)*
<b>Cable Jack Material</b>	Polyurethane
<b>Enclosure Rating</b>	NEMA 4 (IP65) faceplate
<b>Enclosure Material</b>	Polycarbonate
<b>Enclosure Mount</b>	Panel
<b>Button Material</b>	Silicon rubber
<b>Classification</b>	General purpose
<b>Weight (lbs)</b>	0.6
<b>Compliance</b>	CE, RoHS

## Features

- Operates with all EchoPod DL, DS and DX series level sensors compatible with WebCal 6.0 software / firmware 50.0 or higher
- No separate power supply required
- Use PodView to make simple adjustments to EchoPods sensor settings
- Provides level indication up to 15 feet from sensor
- Corrosion resistant NEMA 4 / IP65 enclosure
- No configuration required for the display. Simply wire the display directly to a programmed compatible EchoPod sensor
- Display can be transferred from sensor to sensor without any configuration changes to the display
- Make quick setpoint changes without the need to connect sensor back to a PC
- Made in the USA

## Agency Approvals

- CE

## Dimensions inches [mm]

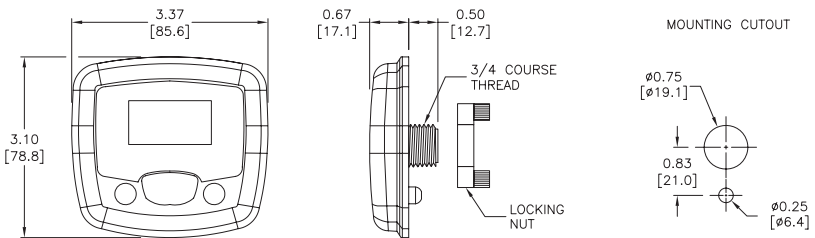

\* Maximum distance between EchoPod sensor and PodView display is 15 ft (4.5m)

See our website [www.AutomationDirect.com](http://www.AutomationDirect.com) for complete Engineering drawings.

## Configuration

The settings for the the EchoPod DL, DS and DX series are configured with free WebCal software (downloadable from AutomationDirect Web site) and an LI99-2001 Fob USB adapter (purchased separately). To be compatible with PodView the EchoPod DL, DS and DX sensor must be configured with WebCal 6.0 / firmware 50.0 or higher.

## Wiring

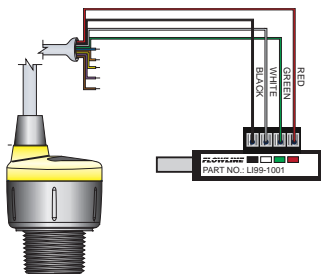

See the WebCal software catalog page in this section for further details



EchoPod® DL, DS and DX series



LI99-2001

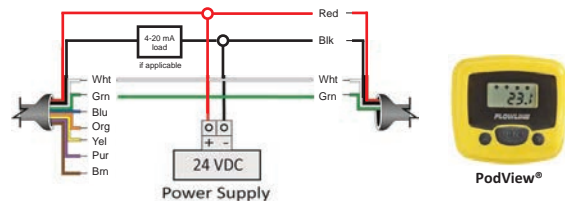

Note: Maximum distance between EchoPod sensor and PodView display is 15 ft. (4.5m)



# WebCal Ultrasonic Level Sensor Software and USB Fob Adapter

## Overview



WebCal PC software is a utility program that allows users to easily configure their EchoPod, EchoTouch and EchoSonic II level transmitters, switches, and controllers. Download your free copy of WebCal at [www.AutomationDirect.com](http://www.AutomationDirect.com), and connect your sensor through the Fob USB adapter (LI99-2001). Develop your configuration using pre-programmed function menus as the tank graphic and set point fields automatically change to match your configuration. Then, input your level set point values and click the Write to Unit button. Your configuration will be downloaded into the sensor and verified in less than a second. Last, click the Wiring Diagram button to open a wiring schematic of your configuration in PDF format. Print the document, disconnect the sensor and wire it per the schematic. It's that simple.

Configuration files can be named, saved, emailed, printed, opened and used again under revision control. The advanced feature page enables you to change the measurement signal, output filtering and invert relay states from N.O. to N.C. As new software or firmware becomes available, they can be downloaded and updated through WebCal.

## Features

- 169 configurations with pull-down menu selections
- Graphical interface lets you visualize your configuration
- Applicable level set point fields appear automatically
- Installs and tests configuration in less than a second
- Available PDF wiring diagram for each configuration
- Technical help menu with FAQs, tips and glossary
- Rapidly program sensors to the same configuration
- Save configuration files for future use or reference
- Print wiring diagrams and configuration text files
- Email configuration files to other remote users
- Made in the USA

Please check [www.automationdirect.com](http://www.automationdirect.com) for the most recent system requirements.

WebCal Ultrasonic Level Sensor Software and USB Adapter					
Part No.	Item Photo	Description	Quantity	Weight (lbs)	Price
LI99-2001		Flowline Fob USB adapter, required for use with WebCal software to configure Flowline EchoPod, EchoTouch and EchoSonic II ultrasonic level sensors.	1	0.1	\$42.50
WEBCAL		Configuration software CD for Flowline EchoPod, EchoTouch and EchoSonic II ultrasonic level sensors (also available as a free download from the AutomationDirect Web site). Requires an LI99-2001 Fob USB adapter (purchased separately).	1	0.1	\$9.75

### EchoPod Configuration

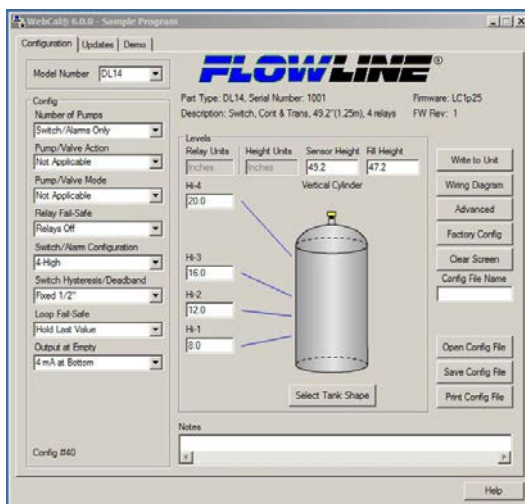

### EchoSonic II Configuration

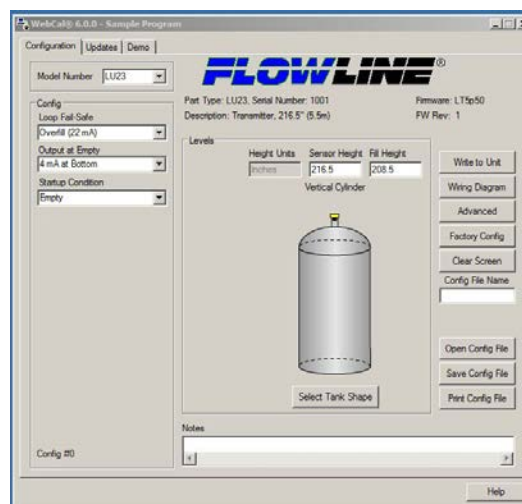

Click on the thumbnail or go to <https://www.automationdirect.com/VID-LE-0004> for Part 1 of our How To video on the use of the Flowline Ultrasonic Level Sensors



Click on the thumbnail or go to <https://www.automationdirect.com/VID-LE-0005> for Part 2 of our How To video on the use of the Flowline Ultrasonic Level Sensors





# Ultrasonic Liquid Level Sensor Accessories

Ultrasonic Liquid Level Sensor Accessories					
Part No.	Item Photo	Description	Quantity	Weight	Price
LI40-1001		Flowline PodView general purpose digital indicator, displays tank level or volume and sensor relay status, 6-digit LCD display with four relay status indicators, 3-button user interface, polycarbonate panel mount enclosure with NEMA 4 (IP65) faceplate, 6-foot (1.8-meter) 22AWG 4-conductor cable, for use with Flowline EchoPod DL, DS and DX series ultrasonic level sensor with firmware V50.0 or later	1	0.6	\$206.00
LM50-1001		Flowline side mount bracket, 2 inch NPT female threads, polypropylene (PP), for use with Flowline DL34, LU23, LU28, LU29, LU74, LU78, LU81, LU83, LU84, UG01, UG03, UG06, US01, US03 and US06 series ultrasonic level sensors	1	0.4	\$34.00
LM50-1001-1		Flowline side mount bracket, 2 inch NPT female threads, polypropylene (PP), and 2 inch NPT male x 1 inch NPT female reducer bushing (PVC), for use with Flowline DL14, DL24, DS14, DL10, DX10, LU27, LU77 and LU80 series ultrasonic level sensors	1	0.6	\$43.50
LM52-1400		Flowline reducer bushing, 2 inch NPT male x 1 inch NPT female threads, PVC, for use with Flowline DL14, DL24, DS14, DL10, DX10, LU27, LU77 and LU80 series ultrasonic level sensors	1	0.2	\$14.00
LM52-2400		Flowline reducer bushing, 3 inch NPT male x 2 inch NPT female threads, PVC, for use with Flowline DL34, LU23, LU28, LU29, LU74, LU78, LU81, LU83, LU84, UG01, UG03, UG06, US01, US03 and US06 series ultrasonic level sensors	1	0.6	\$30.50
LM52-3800		Flowline reducer bushing, PVC, 4in male NPT to 2in female NPT. For use with Flowline DL34, LU23, LU28, LU29, LU74, LU78, LU81, LU83, LU84, UG01, UG03, UG06, US01, US03 and US06 series ultrasonic level sensors	1	2.0	\$99.00
LM52-1890		Flowline low-profile bulkhead fitting, 1 inch NPT female x slip socket, with mounting nut, PVC, for use with Flowline DL14, DL24, DS14, DL10, DX10, LU27, LU77 and LU80 series ultrasonic level sensors	1	0.5	\$43.50
LM52-2890		Flowline low-profile bulkhead fitting, 2 inch NPT female x slip socket, with mounting nut, PVC, for use with Flowline DL34, LU23, LU28, LU29, LU74, LU78, LU81, LU83, LU84, UG01, UG03, UG06, US01, US03 and US06 series ultrasonic level sensors	1	1.2	\$73.00
LM52-1850		Flowline mounting flange, 1 inch NPT female threads, CPVC, for use with Flowline DL14, DL24, DS14, DL10, DX10, LU27, LU77 and LU80 series ultrasonic level sensors	1	0.5	\$43.50
LM52-2850		Flowline mounting flange, 2 inch NPT female threads, CPVC, for use with Flowline DL34, LU23, LU28, LU29, LU74, LU78, LU81, LU83, LU84, UG01, UG03, UG06, US01, US03 and US06 series ultrasonic level sensors	1	1.0	\$63.00
204038		Replacement mounting gasket, for use with Flowline DL14, DL10, DX10 and DS14 series ultrasonic level sensors	1	0.1	\$5.25
200128		Replacement mounting gasket, for use with Flowline DL24, LU27, LU77 and LU80 series ultrasonic level sensors	1	0.1	\$9.50
200129		Replacement mounting gasket, for use with Flowline DL34, LU23, LU28, LU29, LU74, LU78, LU81, LU83 and LU84 series ultrasonic level sensors	1	0.1	\$14.00

*When installing the 1" NPT level sensors care should be used to mechanically isolate the sensor housing from the tank. This can easily be done by using any of the Flowline mounting accessories which are designed to provide the isolation needed.*



# Ultrasonic Liquid Level Sensor Accessories

## Dimensions

inches [mm]

### LM50-1001

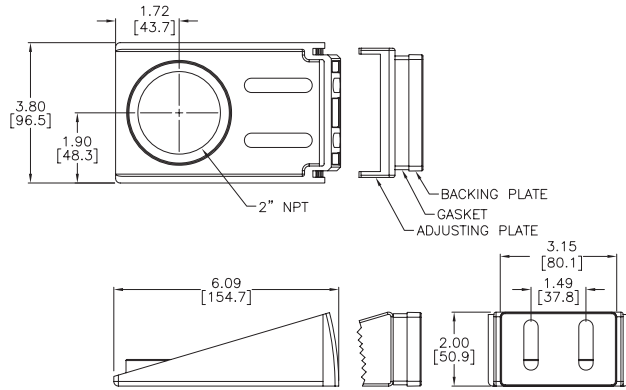

### LM50-1001-1

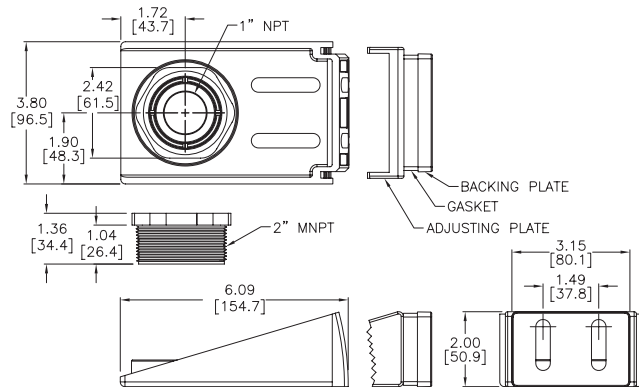

### LM52-1400

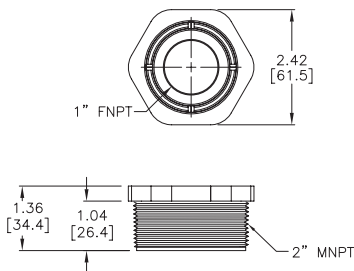

### LM52-2400

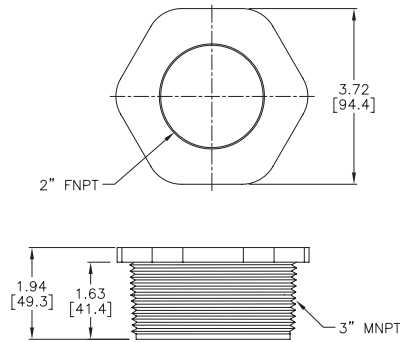

### LM52-3800

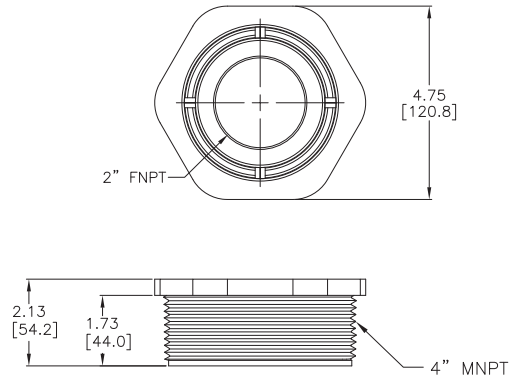

### LM52-1890

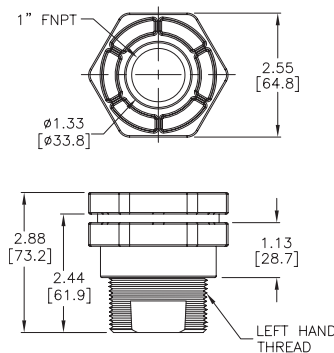

### LM52-2890

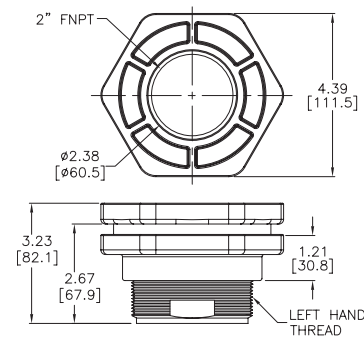

See our website [www.AutomationDirect.com](http://www.AutomationDirect.com) for complete Engineering drawings.



# Ultrasonic Liquid Level Sensor Accessories

## Dimensions inches [mm]

**LM52-1850**

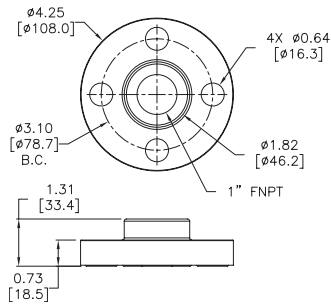

**LM52-2850**

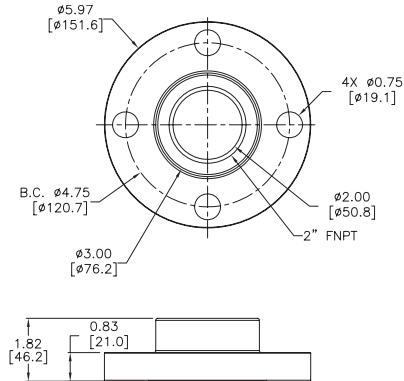

See our website [www.AutomationDirect.com](http://www.AutomationDirect.com) for complete Engineering drawings.